

ATLANTIC

BREATHING AIR
according to DIN EN 12021

DELIVERY
l/min 100 - 60
m³h 6 - 3,6

PRESSURE
BAR 225 / 330
PSI 3250 / 4800

 **NARDI**
COMPRESSORI
BREATHING AIR

High

*Pressure
Quality
Performance
Money savings*



Quality system certified
to iso 9001

All technical data may be changed

MADE IN ITALY BY NARDI COMPRESSORI

www.nardicompressori.com

ATLANTIC P - G

BREATHING AIR is a product line that includes several products made by NARDI COMPRESSORI designed to provide breathing air for the filling of cylinders scuba diving. ATLANTIC is a compressor with very high efficiency and mechanically strong but at the same time compact and light.

QUALITY OF COMPRESSOR BLOCK

The compressor block or pump unit is the heart of the ATLANTIC compressor. This is a critical component in which NARDI has put particular attention. It has features that make it unique in the world. Among these, the use of light alloys with high thermal efficiency, such as aluminum alloys that are also used for the construction of the cylinders. The pump unit does not undergo any paint coating to enhance the heat dissipation of its low corrosion assembling elements.

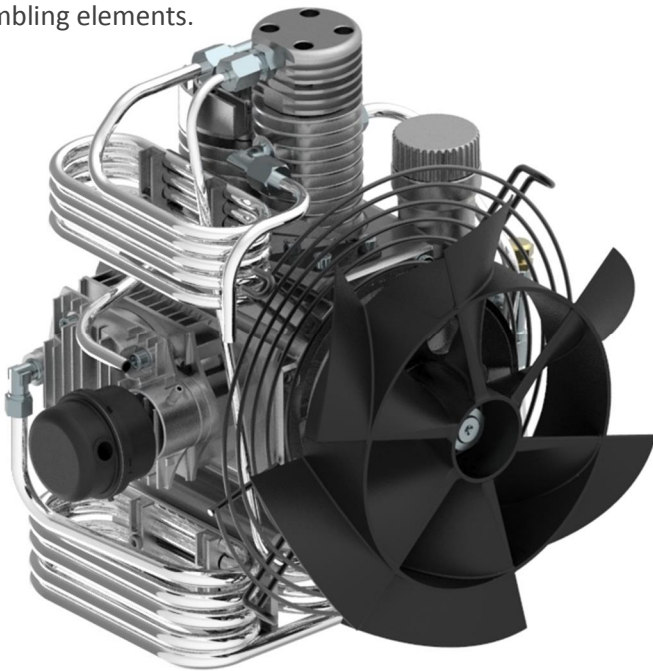

The bearings of the crankshaft are all European made which guarantee a long life of the compressor. Cooling of the compressed air is done through the inter-stage aluminium and stainless steel cooling coils. This is a small compressor with 4 compression stages and all the piston rings are made in cast iron providing high performance over time.

EFFICIENCY OF THE FRAME

The frame is designed to reduce weight and dimensions, making the compressor light and portable, with an aluminium frame that is coated with epoxy powder paint. The powder coating and stainless steel components protect the compressor against corrosion also in marine environments.

PURITY OF FILTRATION

The compressor is equipped with a filter and a separator. In addition to the separator, the machine has a filter that guarantees the quality of breathing air in conformity with the standard UNI EN 12021:2014.

ECONOMY

Everything in the compressor is designed to optimize both the operating costs as well labour costs.

When the compressor is in operation to optimize the cost NARDI has designed the automatic condensate drain of the compressor, which is equipped with a unique patented SLOW FLOW SYSTEM, that reduces the quantity of gas expelled by 80% saving on pressurization of the entire system.

FILLING VALVES

The compressor is equipped with high pressure filling valves with several different connectors are requested by the client both for 200 Bar as for 300 Bar. The construction of this component makes it easier to use. In fact, with a simple turn of the knob you can close the passage of air and depressurize the valve to be able to remove the cylinder.

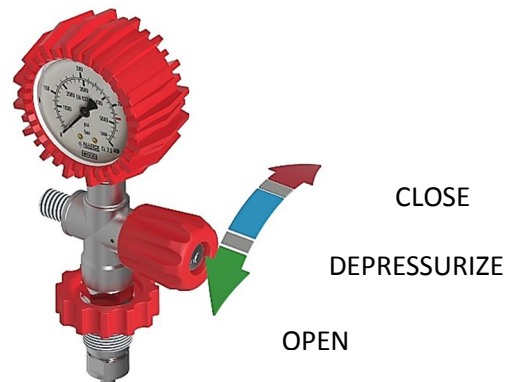

All technical data may be changed

MADE IN ITALY BY NARDI COMPRESSORI

www.nardicompressori.com



water resistant frame
aluminum - stainless steel

- 1 Intake Filter
- 2 Compressor Block
- 3 Flywheel Cover
- 4 Interstage Separator
- 5 Filter ATL
- 6 Pressure Maintaining Valve
- 7 Filling Hose Connections (Maximum 2)
- 8 Filling valve with Pressure Gauge

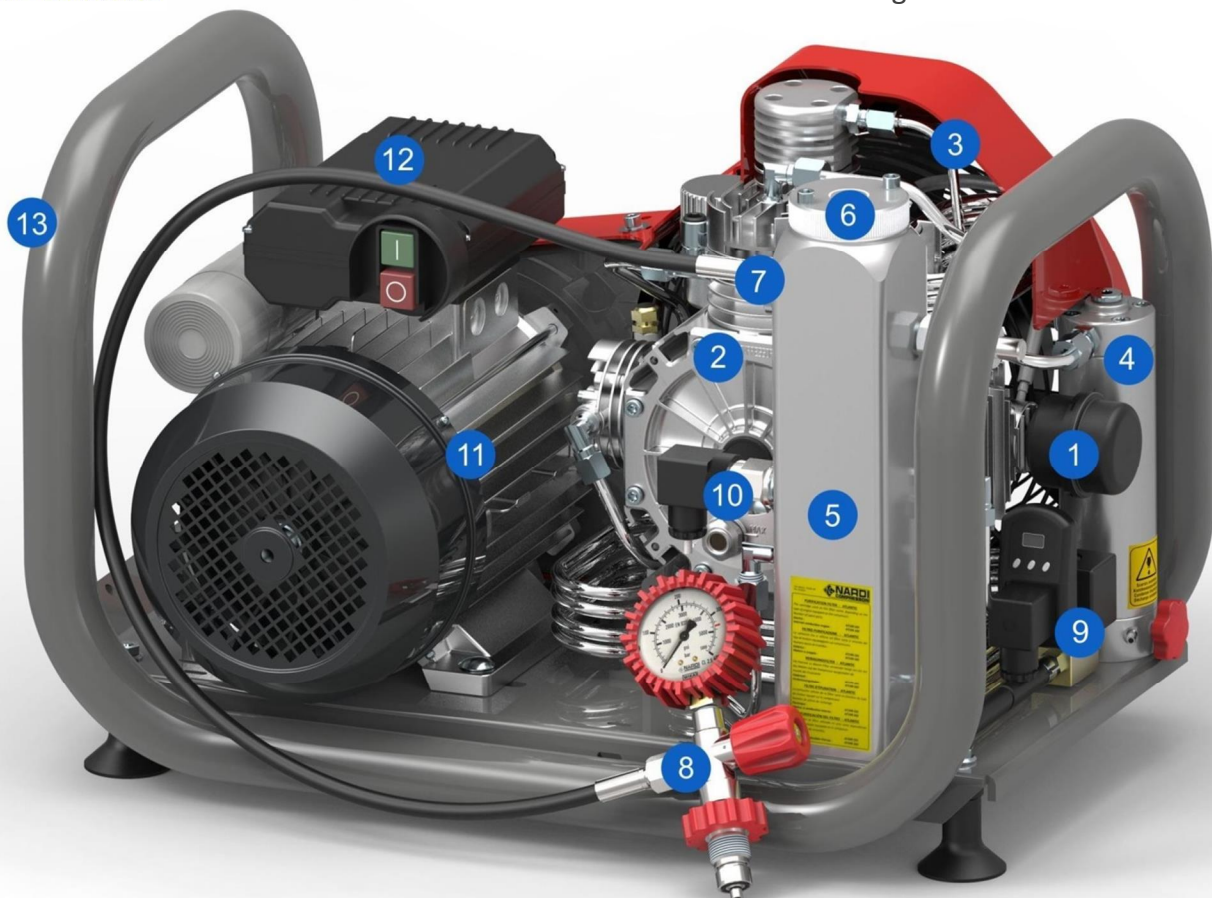

- 9 Automatic Condensate Drain (Optional)
- 10 Final Pressure Switch with Autostop (Optional)
- 11 Electric Motor
- 12 Hour Meter (Optional)
- 13 Frame in aluminium powder paint coated

OPTIONAL

Compressor model

One additional filling hose (standard 1 filling hose, maximum 2 filling hoses)

Final pressure switch with autostop

Automatic Condensate Drain

Dual Pressure, 225 bar (max. 1 filling hose) + 330 bar (max. 1 filling hose)

Trolley (wheels + handle)

All technical data may be changed

MADE IN ITALY BY NARDI COMPRESSORI

www.nardicompressori.com

ATLANTIC P



NARDI
COMPRESSORI
BREATHING AIR



ATLANTIC G



Gasoline Fuel



Model Compressor	Engine	Charging rate		Filtration	Filling time	STAGE	Revolution	Power		Noise	Weight		Dimension
Modello Compressore	Motore	Aria resa		Filtro	Tempo di carica	Stadi	Giri	Motore		Rumore	Peso		Dimensioni
Type	Type	l/min.	m ³ /h	Mod.	10 Litri / 200 bar	N°	Rpm	HP	Kw	dB	Kg	Lbs	cm (LxWxH)
ATLANTIC P 60	mono-phase	60	3,6	ATL	33 min	4	2100	2,0	1,5	76	39,5	87	58 x 41 x 41
ATLANTIC P 100	mono-phase	100	6	ATL	20 min	4	2100	3,0	2,2	79	42	93	58 x 41 x 41
ATLANTIC P 100	three-phase	100	6	ATL	20 min	4	2100	3,0	2,2	79	42	93	58 x 41 x 41
ATLANTIC G 100	gasoline	100	6	ATL	20 min	4	2100	6,0	4,2	84	42	93	76 x 41 x 41

NARDI COMPRESSORI SRL

Via Marco Polo, 2
36075 Montecchio Maggiore (VI) ITALY

Phone +39 0444 159111

Fax +39 0444 159122

SUBJECT TO TECHNICAL MODIFICATIONS

info@nardicompressori.com

www.nardicompressori.com