

HYDRAULIC STEERING SYSTEMS FOR OUTBOARD MOTORS

2021



Lecomble & Schmitt s.A.s.

BP N° 2
64240 URT – France

Sales Department: 33 (0) 559 56 24 11 - commercial@ls-france.com

Technical Department: 33 (0) 559 56 26 46 - commercial2@ls-france.com

Fax : 33 (0) 559 56 95 71

<http://www.ls-france.com>

CONTENTS

	Pages
• Introduction – Description	2
• Working Principle	3
• Selection of the Steering System	3
• Different Types of Assemblies	4
• Outboard Hydraulic Steering Main Components	5
• Hydraulic Steering System for Maximum Power 80 H.P.	6
• Hydraulic Steering System for Maximum Power 125 H.P.	7
• Hydraulic Steering System for Maximum Power 175 H.P.	8
• Hydraulic Steering System for Maximum Power 225 H.P.	9
• Hydraulic Steering System for Maximum Power 350 H.P.	10
• Hydraulic Steering System for Maximum Power 700 H.P.	11
• Power Assist Hydraulic Steering for 150 H.P. and over	12 to 13
• Hydraulic Steering System for Maximum Power 115 H.P.	14
• Hydraulic Steering System for Maximum Power 300 H.P.	15
• Side Mounted Hydraulic Steering Systems (maximum power 175 H.P., 300 H.P.)	16
• HB 5 Tilt Pumps	17
• Hydraulic Steering Systems for Stern-Drives	18
• Push-Pull Hydraulic Steering for Race Boats	19
• Cylinders with Tiller for Outboard Motors	20
• Accessories for Outboard Steering Systems	21 to 22
• Range of Steering Wheels	23
• Hydraulic Flexible Tubes and Fittings	24
• Notes	
• Guarantee	

HYDRAULIC STEERING SYSTEMS FOR OUTBOARD MOTORS

INTRODUCTION

LS Hydraulic Steering Systems

Our hydraulic steering systems for outboard motors **are perfectly adapted to the requirements of different applications**, i.e. pleasure boating, workboats, professional or amateur fishing, competition and its accompaniment.

They **are easy to install**, state of the art machine finished and **made to resist a marine environment**.

You can easily select **the best suited system for your boat** within the most comprehensive range available on the market with a guarantee of **efficiency, reliability and smoothness**.

Our systems carry a **2 year warranty** and are **CE** approved.

DESCRIPTION OF LS HYDRAULIC STEERING SYSTEMS

As a general rule, the basic set up of a steering system includes:

- 1 Cylinder,
- 1 Manual pump,
- Fittings and tubing to connect the cylinder to the manual pump.

Other elements will be added to this basic set up in function of the number of steering stations, the number of outboard motors to be operated and the addition of a power pack for the automatic pilot.

Cylinder

The cylinder is the dictating element towards the selection of a system as it gives the power to the steering system. To select a cylinder, follow the method described on page 3.

Manual pump

The manual pump is an axial piston pump which sucks and forces back the oil contained in the circuit when the wheel is operated. Its cubic capacity determines the number of turns required for a lock to lock manoeuvre of the motor(s). The pump is fitted with lock valves to prevent inopportune motor movement when the helm is not operated. The pump is also fitted with pressure relief valves to protect the circuit against abnormal pressure increase.

Tubing

Tubing is designed for hydraulic transfer under pressure and is easily integrated in the installation as a result of its flexibility and small bending radius. Tubing diameter is selected in function of the manual helm pump flow rate.

HYDRAULIC STEERING SYSTEMS FOR OUTBOARD MOTORS

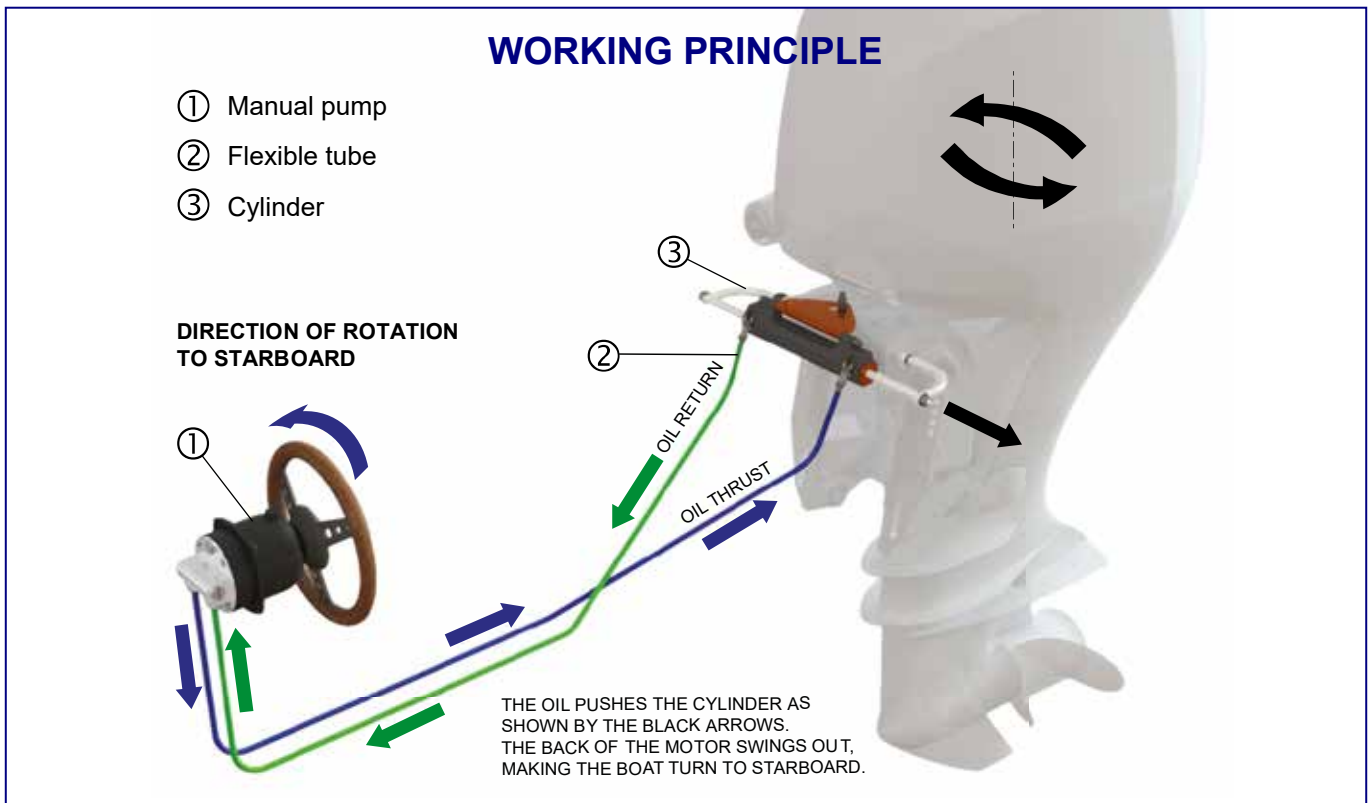

SELECTION OF THE STEERING SYSTEM

To select a steering system in our range, first determine the maximum horse power developed by the outboard motor(s) and the rotational direction of the propellers on installations with several motors.

Indeed:

- **For twin motor installations working in the same rotational direction, add the power of both motors** (see example below).

Whereas:

- **For twin motor installations working in counter-rotation, take into account the power of one motor only + 20%** (see example below).

	Maximum Power
For the installation of one single motor 1 x 115 H.P.	= 115 H.P.
For twin motor installation 2 x 115 H.P. (same rotational direction)	= 230 H.P.
For twin motor installation 2 x 115 H.P. (in counter rotation) : 115 + 20%	= 138 H.P.

Now select in our range the hydraulic steering which complies with the **maximum power** of the motor(s) (see examples below):

Maximum power 115 H.P.	LS 125 PRO or LS 226
Maximum power 230 H.P.	LS 3500 PRO or LS 232 C
Maximum power 138 H.P.	LS 175 PRO

For twin motor installations when the calculated maximum power exceeds the **maximum power** the steering system is given for (ex.: 2 x 200 H.P. in same rotational direction = 400 H.P.), it will be necessary to install a cylinder on each motor with a parallel hydraulic circuit (see "Different types of assemblies" on page 4).

Note: For 4-blade propellers or more and for motors equipped with twin propellers or with long or extra-long shafts, please contact us.



DIFFERENTS TYPES OF ASSEMBLIES

Single-motor installations

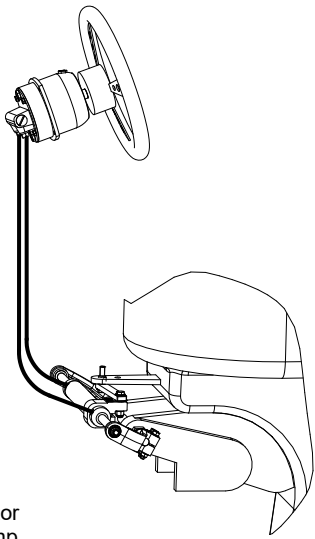

- 1 motor
- 1 pump
- 1 front mount cylinder

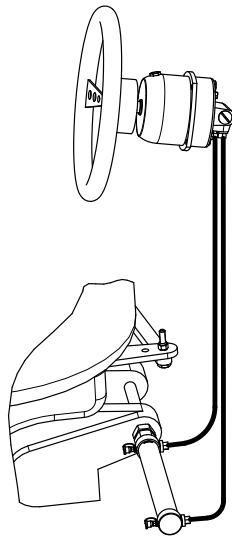

- 1 motor
- 1 pump
- 1 side mount cylinder

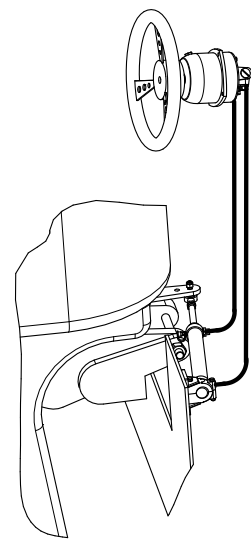

- 1 motor
- 1 pump
- 1 side mount cylinder on panel

Twin-motor installations

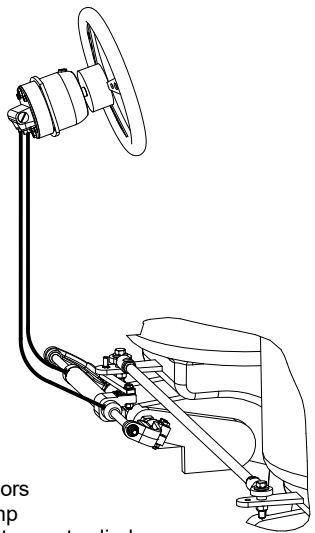

- 2 motors
- 1 pump
- 1 front mount cylinder
- 1 tie rod

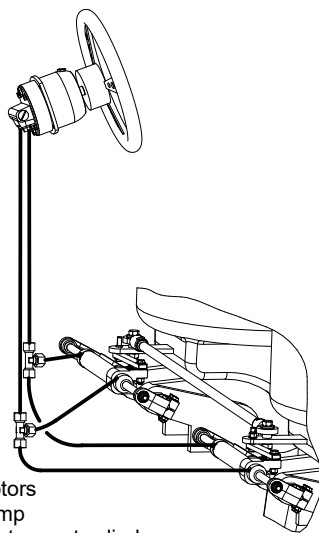

- 2 motors
- 1 pump
- 2 front mount cylinders
- 1 tie rod

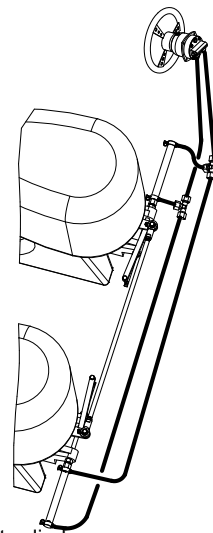

- 2 motors
- 1 pump
- 2 side mount cylinders
- 1 tie rod

Installation for double steering station

Traditional installation with T-fittings

Non vented plug compulsory

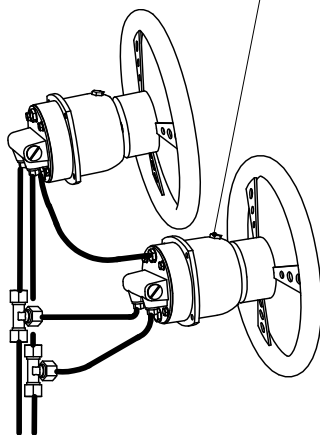

Installation with dual outlet pump flange (horizontal / vertical)

Non vented plug compulsory

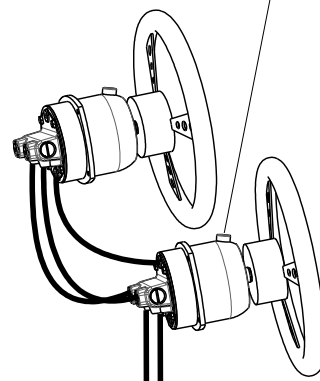

HYDRAULIC STEERING SYSTEMS FOR OUTBOARD MOTORS

OUTBOARD HYDRAULIC STEERING MAIN COMPONENTS

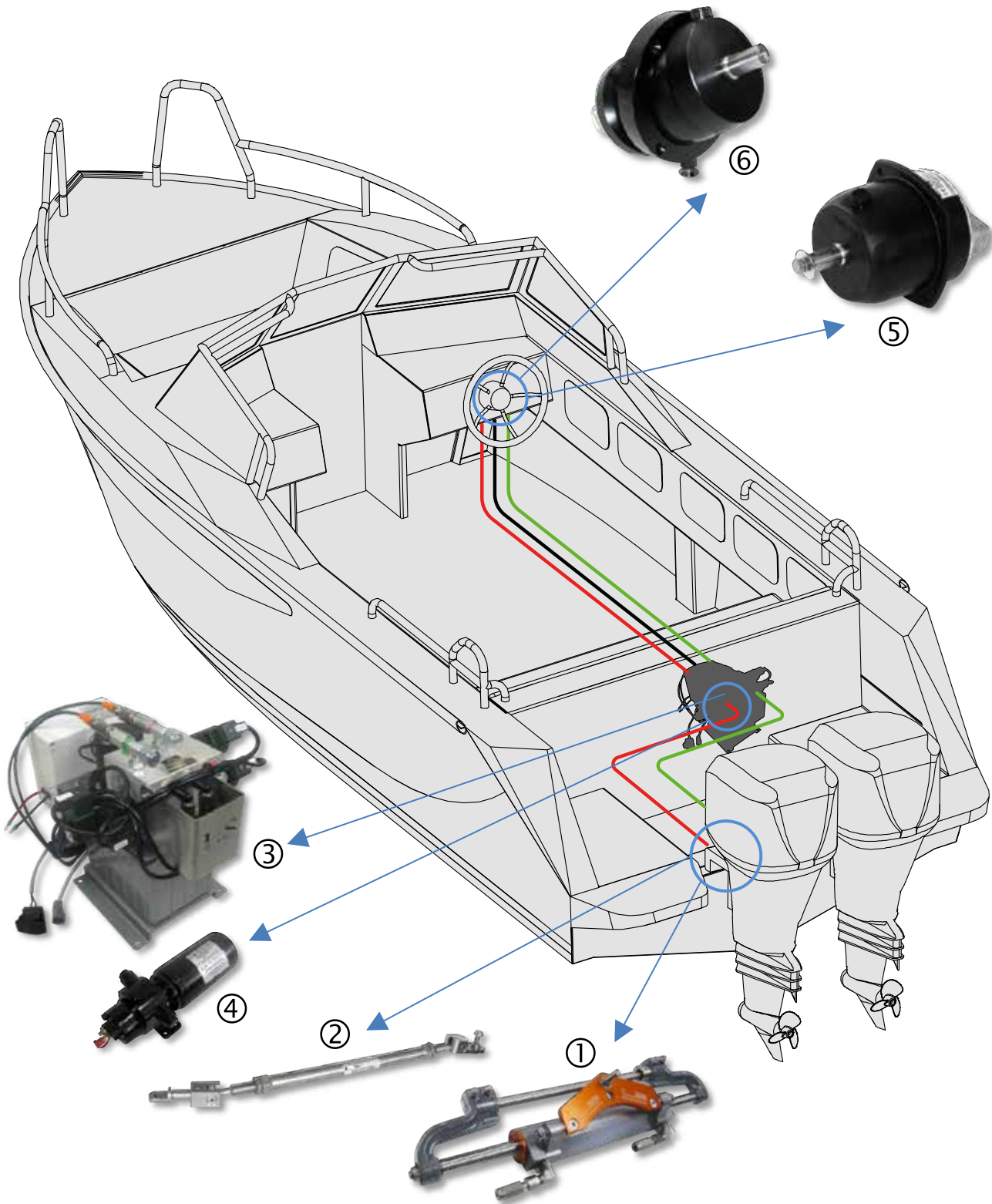

① Hydraulic cylinder

④ Autopilot power pack

② Tie rod for multi-engine installation

⑤ Hydraulic helm pump

③ Autopilot and power assist power pack

⑥ Tilt pump (multi-position)

HYDRAULIC STEERING SYSTEM LS 80 PRO – 2203348

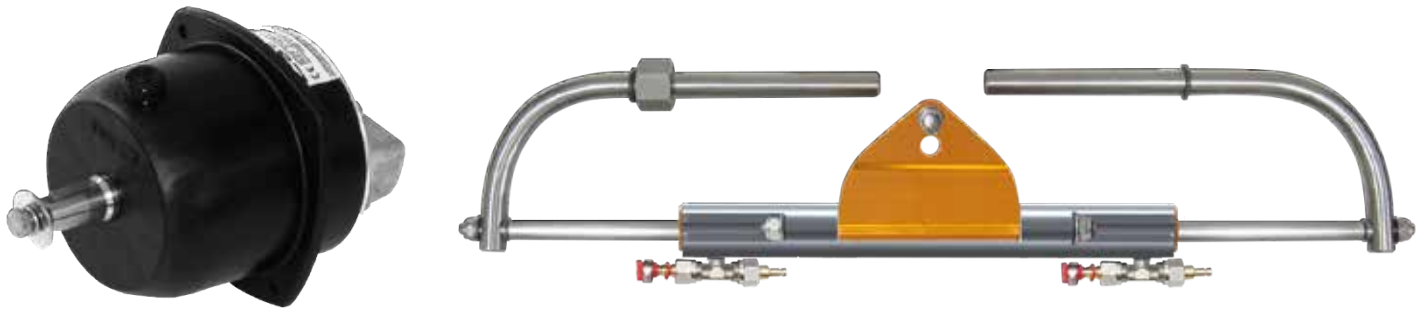

FOR OUTBOARD MOTORS UP TO 80 HP / PORT TO STARBOARD: 3.5 turns
contact us for boat speed exceeding 40 knots and for 40 / 50 hp Suzuki motors

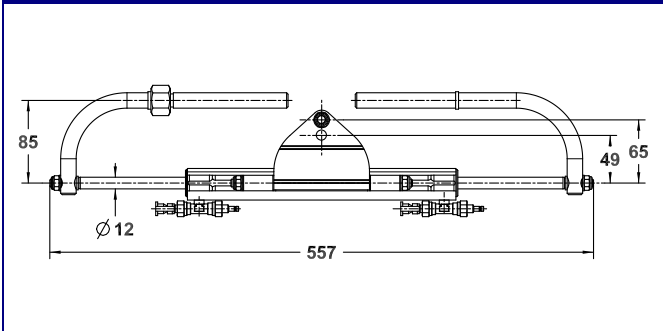

2203315 VHM EX 80 HP + fittings
 Weight: 2.3 kg Volume: 70 cc Stroke: 206 mm

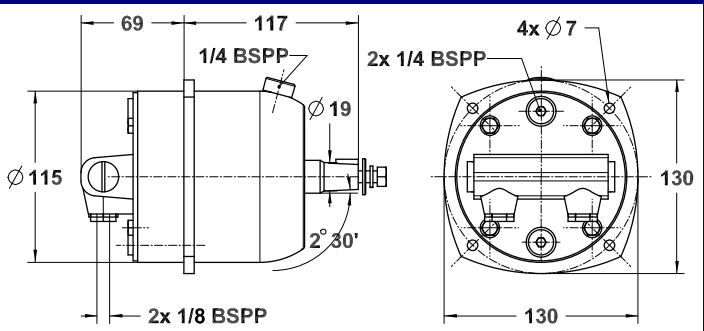

2200804 20 HB with lock valve
 Weight: 2.8 kg

Composition of standard kit 2203348

- 2200804** Pump 20 HB with lock valve
- 2203315** Cylinder VHM EX 80 HP + fittings
- 2201989** Set of elbow pump fittings Ø 6
- 1204268** 10 metres of flexible tube Ø 6
- 2203853** OB filling kit

OPTION

2203658 HB 5 Tilt Pump - 20 CT – *page 17*

ACCESSORIES

STEERING WHEELS – page 23

PUMP BEZEL – page 21

OIL CAN – page 21

BULKHEAD STRAIN RELIEF – page 21

TIE RODS – page 22

HYDRAULIC STEERING SYSTEM LS 125 PRO – 2203349



FOR OUTBOARD MOTORS UP TO 125 HP / PORT TO STARBOARD: 5.4 turns
 (200 H.P. for two motors working in counter-rotation)
contact us for boat speed exceeding 40 knots and for 40 / 50 hp Suzuki motors

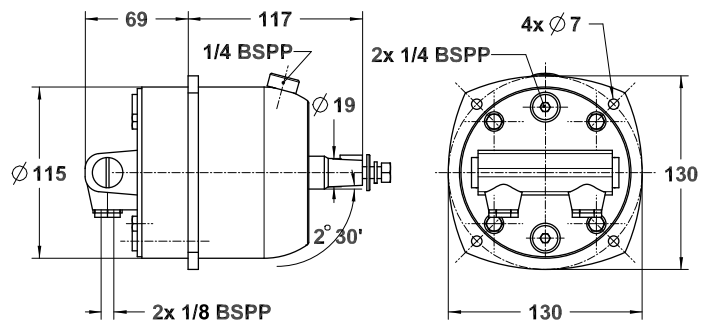
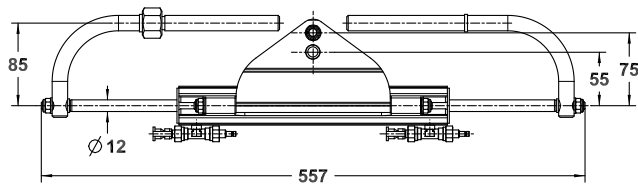

2203333 VHM EX 125 HP + fittings
 Weight: 2.8 kg Volume: 107 cc Stroke: 212 mm

2200804 20 HB with lock valve
 Weight: 2.8 kg

Composition of standard kit 2203349

OPTION

- 2200804** Pump 20 HB with lock valve
- 2203333** Cylinder VHM EX 125 HP + fittings
- 2201989** Set of elbow pump fittings Ø 6
- 1204268** 10 metres of flexible tube Ø 6
- 2203853** OB filling kit

2203658 HB 5 Tilt Pump - 20 CT – *page 17*

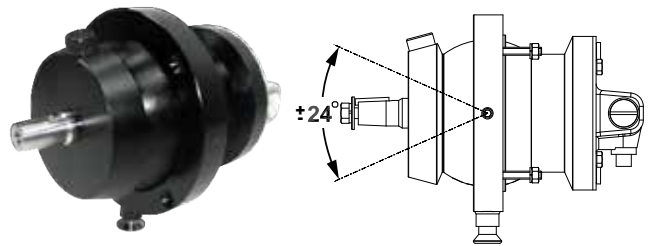

ACCESSORIES

STEERING WHEELS – *page 23*



PUMP BEZEL – *page 21*



ADAPTATION KIT FOR HONDA MOTORS 115, 135, 150 HP – *page 21*



OIL CAN – *page 21*



BULKHEAD STRAIN RELIEF – *page 21*



TIE RODS – *page 22*



HYDRAULIC STEERING SYSTEM LS 175 PRO – 2203350

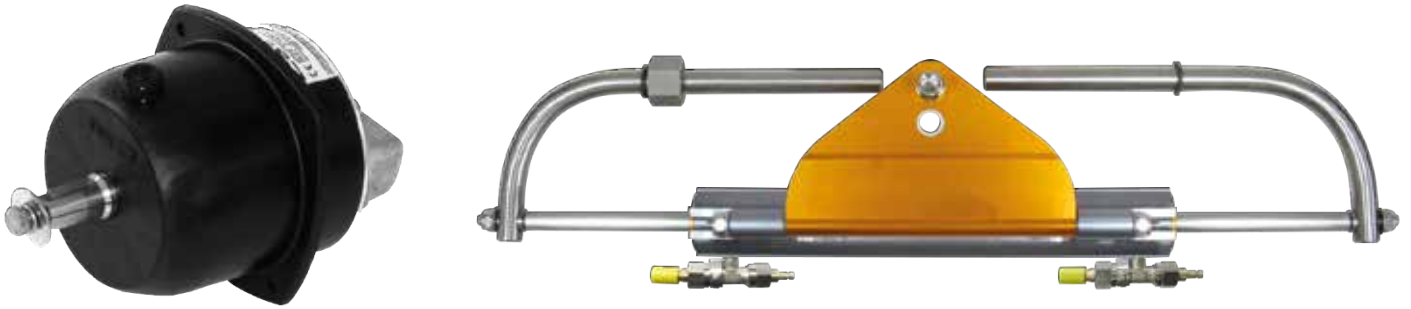

FOR OUTBOARD MOTORS UP TO 175 HP / PORT TO STARBOARD: 5.3 turns
 (300 H.P. for two motors working in counter-rotation)
contact us for boat speed exceeding 40 knots

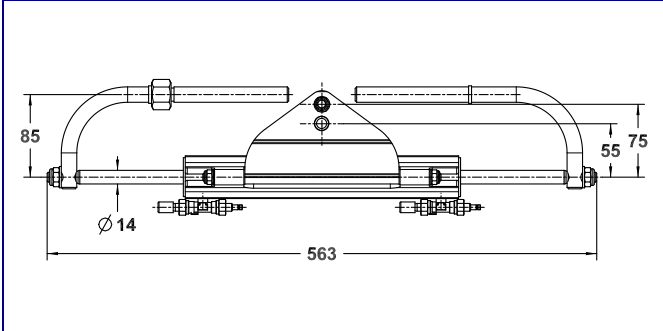

2203334 VHM EX 175 HP + fittings
 Weight: 3.2 kg Volume: 137 cc Stroke: 210 mm

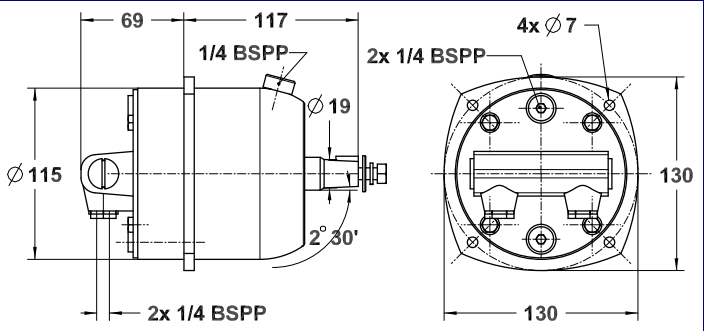

2200948 26 HB with lock valve
 Weight: 2.8 kg

Composition of standard kit 2203350	
2200948	Pump 26 HB with lock valve
2203334	Cylinder VHM EX 175 HP + fittings
2202723	Set of straight pump fit. 1/4 BSPP TS8
1204825	10 metres of flexible tube Ø 8
2203853	OB filling kit

OPTION
2203559 HB 5 Tilt Pump - 26 CT – <i>page 17</i>

ACCESSORIES

STEERING WHEELS – *page 23*

PUMP BEZEL – *page 21*

ADAPTATION KIT FOR HONDA MOTORS 115, 135, 150 HP – *page 21*

OIL CAN – *page 21*

BULKHEAD STRAIN RELIEF – *page 21*

TIE RODS – *page 22*

HYDRAULIC STEERING SYSTEM LS 225 PRO – 2203351

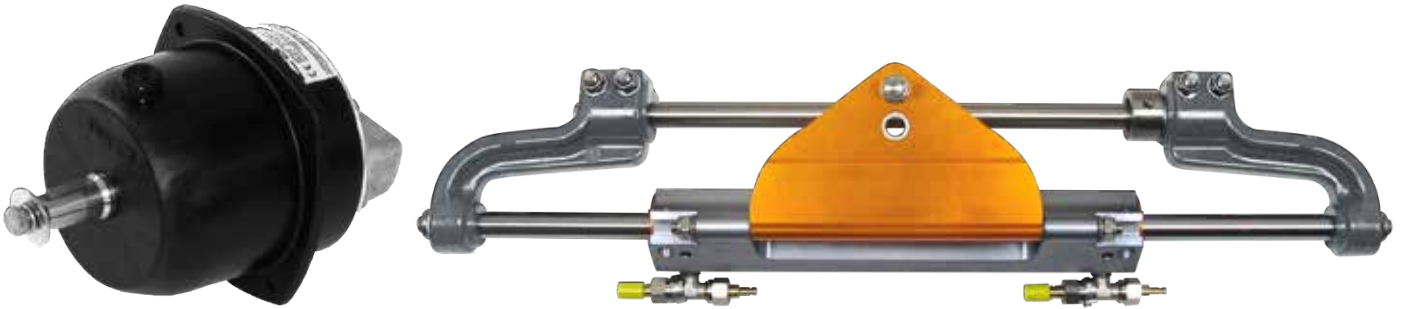

**FOR OUTBOARD MOTORS UP TO 225 HP / PORT TO STARBOARD: 4.9 turns
(400 H.P. for two motors working in counter-rotation)**

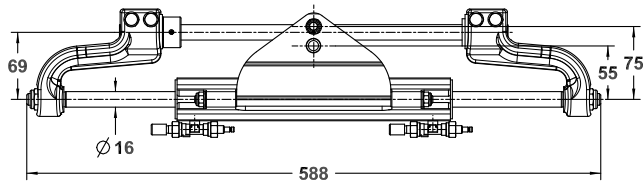

2203335 VHM EX 225 HP + fittings
Weight: 4.1 kg Volume: 127 cc Stroke: 210 mm

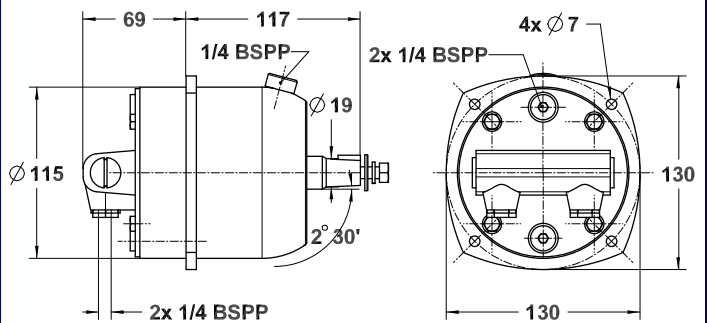

2200948 26 HB with lock valve
Weight: 2.8 kg

Composition of standard kit 2203351

OPTION

- 2200948** Pump 26 HB with lock valve
- 2203335** Cylinder VHM EX 225 HP + fittings
- 2202723** Set of straight pump fit. 1/4 BSPP TS8
- 1204825** 10 metres of flexible tube Ø 8
- 2203853** OB filling kit

2203559 HB 5 Tilt Pump - 26 CT – page 17

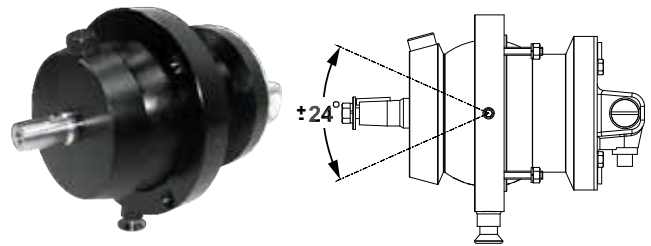

ACCESSORIES

STEERING WHEELS – page 23



PUMP BEZEL – page 21



ADAPTATION KIT FOR HONDA MOTORS 115, 135, 150 HP – page 21



OIL CAN – page 21



BULKHEAD STRAIN RELIEF – page 21



TIE RODS – page 22



HYDRAULIC STEERING SYSTEM LS 3500 PRO – 2203576



**FOR OUTBOARD MOTORS UP TO 350 HP
PORT TO STARBOARD: 6.5 turns**

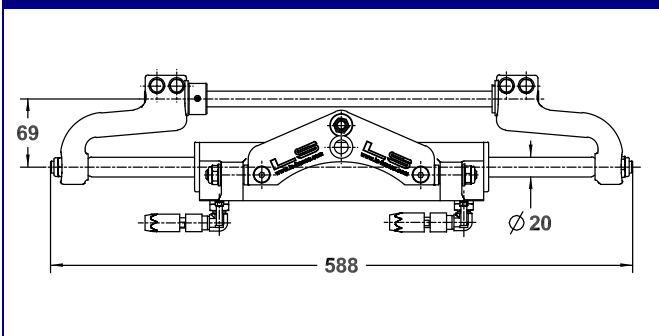

2203572 VHM EX 3500 HP + fittings
Weight: 4.9 kg Volume: 198 cc Stroke: 210 mm

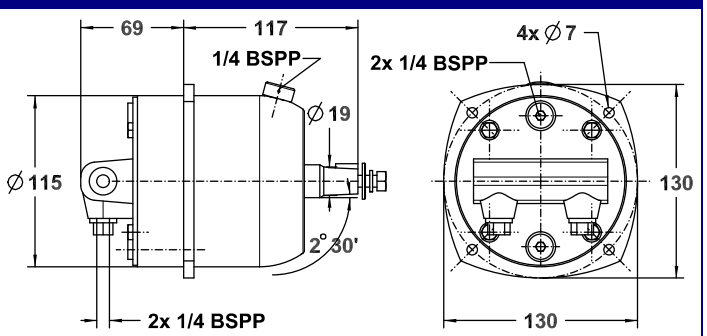

2200950 30 HB with lock valve
Weight: 3.4 kg

Composition of standard kit 2203576		Type of pump		
2200950	Pump 30 HB with lock valve	2200948	2200950	2201105
2203572	Cylinder VHM EX 3500 HP + fittings	26 HB with lock valve(*)	30 HB with lock valve(*)	35 HB with lock valve(*)
2200021	Set of elbow pump fittings	Nb of turns lock to lock		
1204825	10 metres of flexible tube Ø 8	7.5	6.5	5.6
2203853	OB filling kit			

(*) Available in tilt HB 5 version

OPTIONS

2203573 Cylinder VHM EX 3500 HPI with Stainless Steel Bracket + fittings



HB 5 Tilt Pumps – page 17

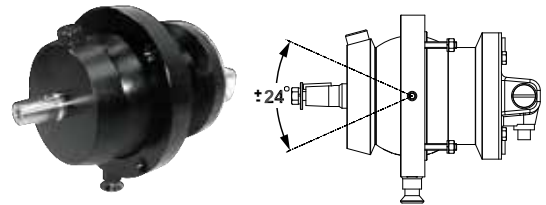

ACCESSORIES

OIL CAN
page 21



PUMP BEZEL
page 21



BULKHEAD STRAIN RELIEF
page 21



STEERING WHEELS
page 23



TIE RODS
page 22



HYDRAULIC STEERING SYSTEM LS 7000 PRO – 2203577

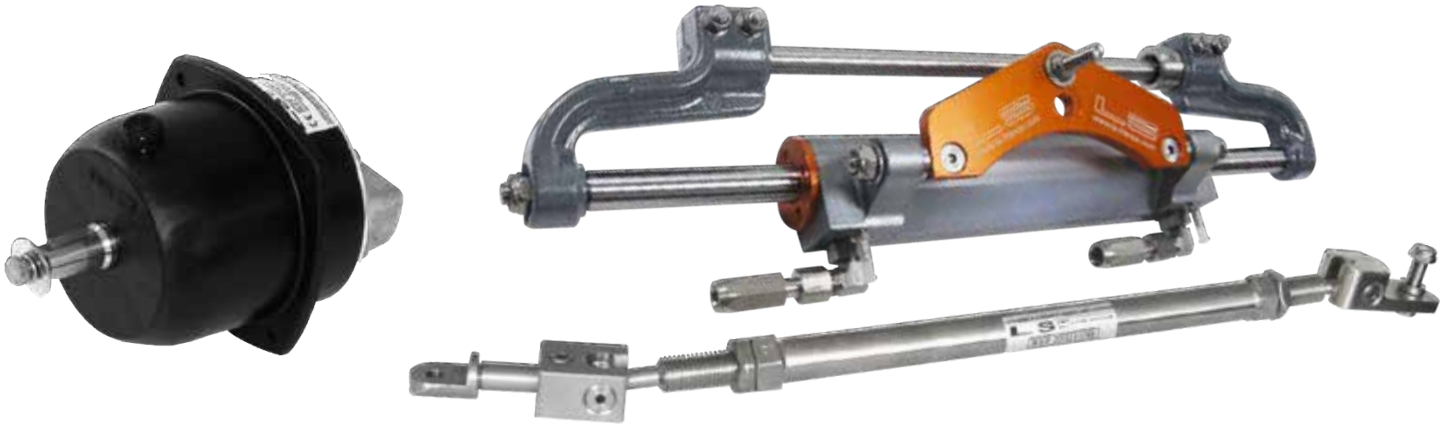

**FOR TWIN OUTBOARD MOTORIZATION IN COUNTER-ROTATION
UP TO 2 x 350 H.P. / PORT TO STARBOARD: 7.5 TURNS**

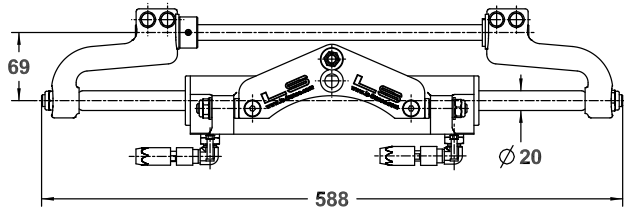

2203572 VHM EX 3500 HP + fittings
Weight: 4.6 kg Volume: 195 cc Stroke: 210 mm

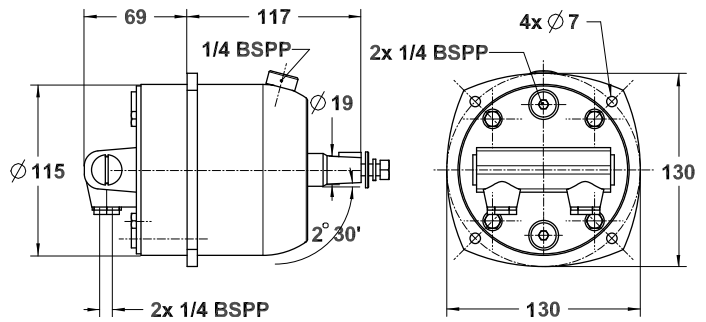

2200948 26 HB with lock valve
Weight: 2.8 kg

Composition of standard kit 2203577		Type of pump		
2200948	Pump 26 HB with lock valve	2202644	2200948	2200950
2203572	Cylinder VHM EX 3500 HP + fittings	20 HB with lock valve	26 HB with lock valve(*)	30 HB with lock valve(*)
2200021	Set of elbow pump fittings	1/4 BSPP(*)		
1204742	12 metres of flexible tube Ø 8	Nb of turns lock to lock		
2202103	350 PRO tie rod Length 580 – 810 mm	10	7.5	6.5
2203853	OB filling kit			

(*) Available in tilt HB 5 version

OPTIONS

2203573 Cylinder VHM EX 3500 HPI with Stainless Steel Bracket + fittings



HB 5 Tilt Pumps – page 17

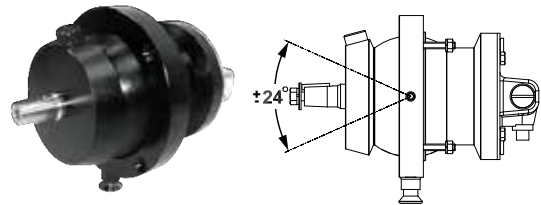

ACCESSORIES

OIL CAN
page 21



PUMP BEZEL
page 21



BULKHEAD STRAIN RELIEF
page 21



STEERING WHEELS
page 23



TIE RODS
page 22



POWER ASSIST STEERING FOR OUTBOARDS WITH INTEGRATED AUTOPILOT FUNCTIONALITY

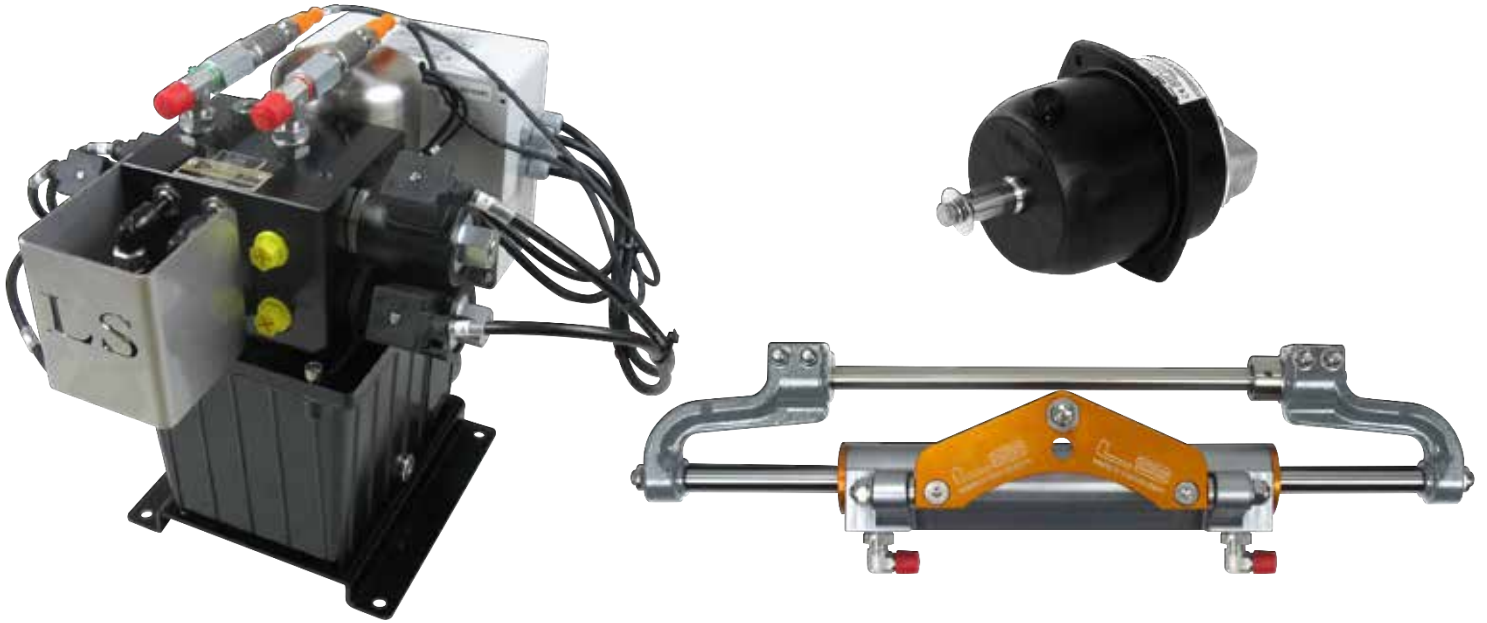

2203854 LS 3500 ASS/30 CC - 3 l/mn - POWER ASSISTED 12 V⁽¹⁾

composed of :

- 1 pump 30 HB with lock valve **2200950**
- 1 power pack unit 3 l/mn 12 V⁽²⁾ **2203800**
- 1 cylinder VHM 3500 HP + s/steel fittings **2203574**
- 1 connection kit **2203856**

2203855 LS 3500 ASS/30 CC - 4.5 l/mn - POWER ASSISTED 12 V⁽¹⁾

composed of :

- 1 pump 30 HB with lock valve **2200950**
- 1 power pack unit 4.5 l/mn 12 V⁽²⁾ **2203841**
- 1 cylinder VHM 3500 HP + s/steel fittings **2203574**
- 1 connection kit **2203856**

⁽¹⁾System requiring high pressure hose (contact us for further information) / ⁽²⁾Available in 24 Volt upon request

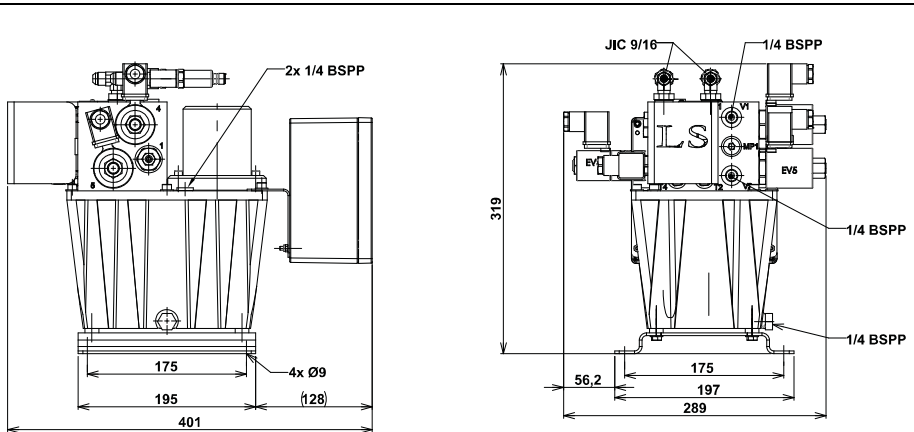
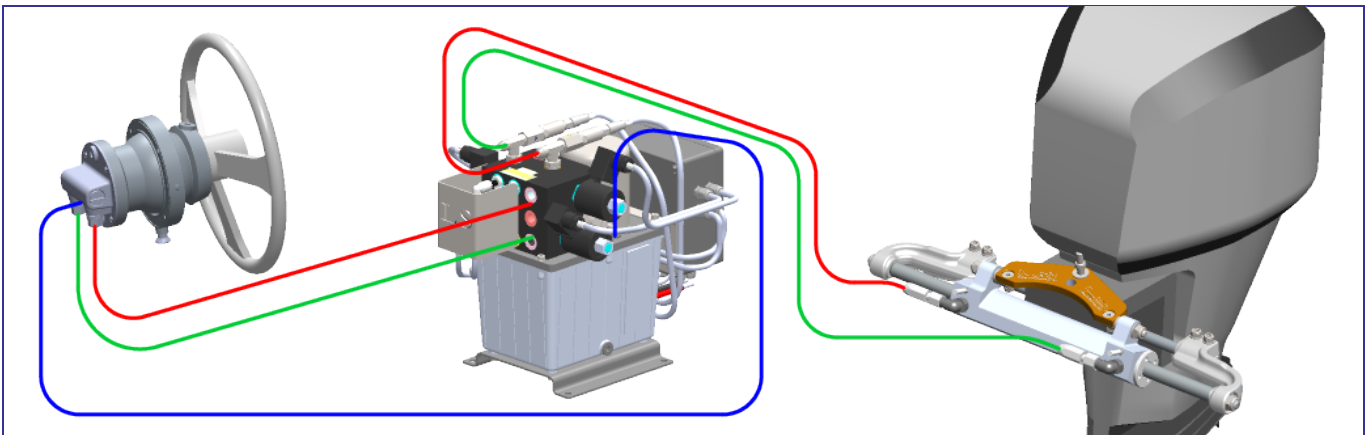

OPTION – page 17

2203659 HB 5 Tilt Pump - 30 CT

±24°

2203800 (3l/mn) / 2203841 (4,5 l/mn) POWER PACK UNIT IN 12/24 V

POWER ASSIST STEERING FOR OUTBOARDS

AUTOPILOT FUNCTIONALITY AVAILABLE IN OPTION



2203829 LS 232 C/40 CC POWER ASSISTED 12 V⁽¹⁾
composed of :

- 1 servo assistance LS 40 - SC **2203820**
- 1 power pack unit 12 V⁽²⁾ **2202762**
- 1 connection kit **2203831**
- 1 cylinder VHM 232 H + s/steel fittings **2202725**

PORT TO STARBOARD 3.5 turns

2203830 LS 3500 PRO/40 CC POWER ASSISTED 12 V⁽¹⁾
composed of :

- 1 servo assistance LS 40 - SC **2203820**
- 1 power pack unit 12 V⁽²⁾ **2202762**
- 1 connection kit **2203831**
- 1 cylinder VHM EX 3500 HP + s/steel fittings **2203574**

PORT TO STARBOARD 4.9 turns

⁽¹⁾System requiring high pressure hose (contact us for further information) / ⁽²⁾Available in 24 Volt upon request

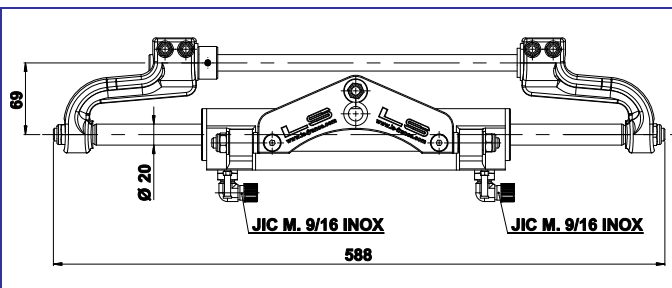
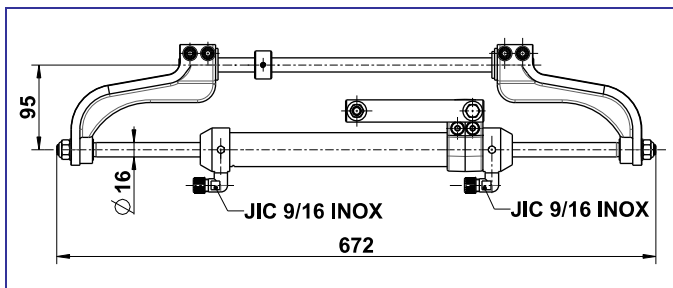

2202725 CYLINDER VHM 232 H + S/STEEL FITTINGS

2203574 CYLINDER VHM EX 3500 HP + S/STEEL FITTINGS

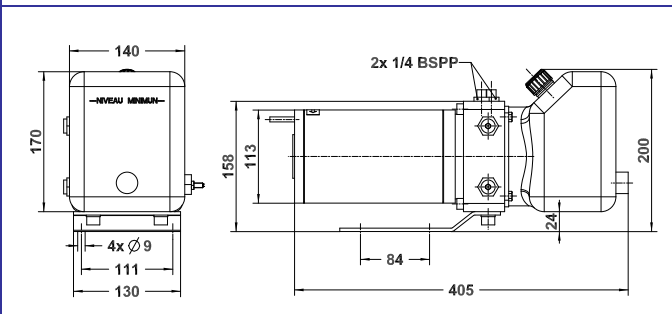
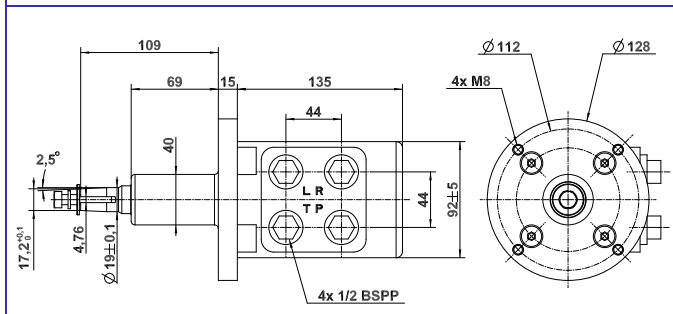

2203820 SERVO ASSISTANCE LS 40 - SC

2202762 POWER PACK UNIT IN 12 V(*)

ACCESSORIES

LS oil, 2 litre can	2200017	Ø8 mm flexible tube (per metre)	2200024
Tie rod 470 – 710 mm (232)	2202041	Bulkhead strain relief	2201753
Tie rod 580 – 810 mm (3500 PRO)	2202103	S/steel motor connect. plate for VHM EX 350 HPI	1206001

HYDRAULIC STEERING SYSTEM LS 226 – 2201757



FOR OUTBOARD MOTORS UP TO 115 HP / PORT TO STARBOARD: 4.8 turns
 (180 H.P. for two motors working in counter-rotation)

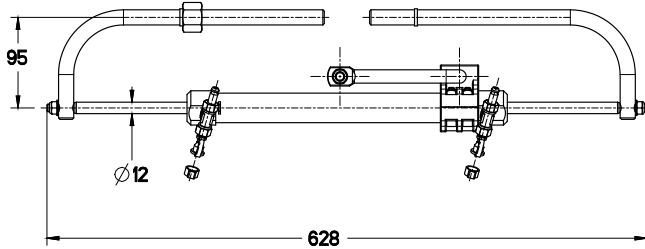

2200830 VHM 226 + fittings
 Weight: 2.6 kg Volume: 96 cc Stroke: 230 mm

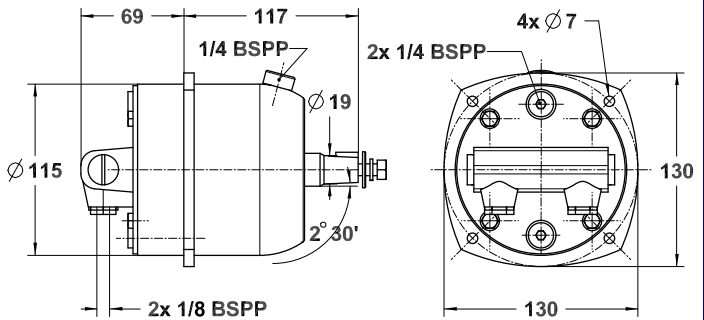

2200804 20 HB with lock valve
 Weight: 2.8 kg

Composition of standard kit 2201757

OPTION

- 2200804** Pump 20 HB with lock valve
- 2200830** Cylinder VHM 226 + fittings
- 2200807** Set of straight pump fittings
- 1204268** 10 metres of flexible tube Ø 6
- 2203853** OB filling kit

- 2203658** HB 5 Tilt Pump - 20 CT – *page 17*

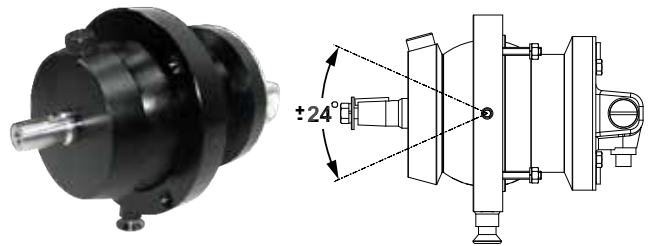

ACCESSORIES

STEERING WHEELS – *page 23*



PUMP BEZEL – *page 21*



OIL CAN – *page 21*



BULKHEAD STRAIN RELIEF – *page 21*



TIE RODS – *page 22*



HYDRAULIC STEERING SYSTEM LS 232 C – 2202224



FOR OUTBOARD MOTORS UP TO 300 HP / PORT TO STARBOARD: 4.7 turns
(500 H.P. for two motors working in counter-rotation)

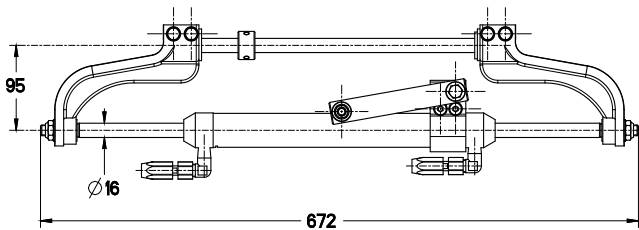

2200696 VHM 232 H + fittings
Weight: 4.2 kg Volume: 140 cc Stroke: 230 mm

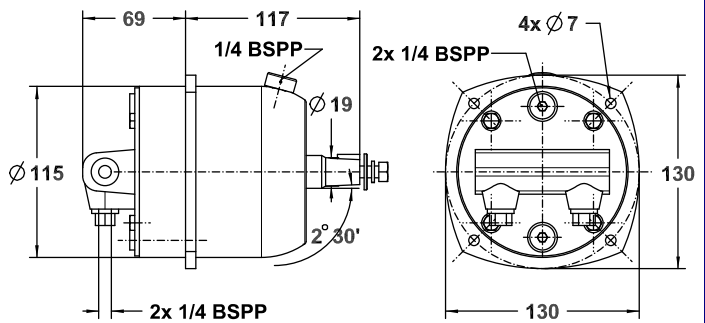

2200950 30 HB with lock valve
Weight: 3.4 kg

Composition of standard kit 2202224		Type of pump		
2200950	Pump 30 HB with lock valve	2202644	2200948	2200950
2200696	Cylinder VHM 232 H + fittings	20 HB with lock valve 1/4 BSPP(*)	26 HB with lock valve(*)	30 HB with lock valve(*)
2200021	Set of elbow pump fittings	Nb of turns lock to lock		
1204825	10 metres of flexible tube Ø 8	7	5.5	4.7
2203853	OB filling kit			

(*) Available in tilt HB 5 version

ACCESSORIES		OPTION
STEERING WHEELS – page 23	PUMP BEZEL – page 21	HB 5 Tilt Pumps – page 17
OIL CAN – page 21	BULKHEAD STRAIN RELIEF – page 21	TIE RODS – page 22

HYDRAULIC STEERING SYSTEMS FOR OUTBOARD MOTORS



SIDE MOUNTED STEERING

Maxi motor power **175 H.P.** **2200951 LS 26 A**
 (Pump 26 HB with lock valve + fitt. + VHM 28 ST HB + fitt + 8m of flex tube)

Maxi motor power **175 H.P.** **2200952 LS 26 B**
 (Pump 26 HB with lock valve + fitt. + VHM 28 ST HBR + fitt + 8m of flex tube)

Maxi motor power **300 H.P.** **2201327 LS 32 HB**
 (Pump 30 HB with lock valve + fitt. + VHM 32 ST HB + fitt + 8m of flex tube)

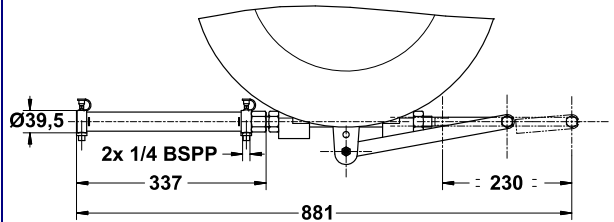

2200033 VHM 28 ST HB **Weight: 1.4 kg**
2200608 VHM 32 ST HB **Weight: 1.4 kg**

Code of elements that can make up a complete kit		Type of pump
2200948	Pump 26 HB with lock valve	2200948 26 HB with lock valve(*)
2200950	Pump 30 HB with lock valve	
2200033	Cylinder VHM 28 ST HB	
2200196	Cylinder VHM 28 ST HBR	
2200608	Cylinder VHM 32 ST HB	
2200021	Set of pump fittings	
2200022	Set of cylinder fittings	
2200038	Set of pump s/steel fittings	2200950 30 HB with lock valve(*)
2200023	Set of cylinder s/steel fittings	
2200047	Set of tees for Ø8 mm flex. tube	
2200024	Ø8 flexible tube (per metre)	
2202041	Tie rod 470 – 710 mm	
2200017	Oil (2 litre can)	

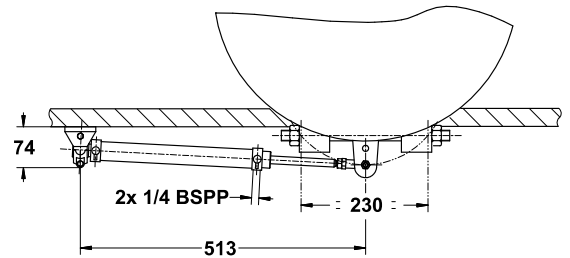

2200196 VHM 28 ST HBR **Weight: 1.1 kg**

OPTION

HB 5 Tilt Pumps – page 17

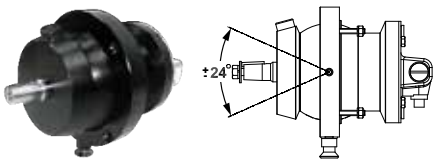

ACCESSORIES

TIE RODS – page 22



STEERING WHEELS – page 23



OIL CAN – page 21



1 motor
1 cylinder
1 pump

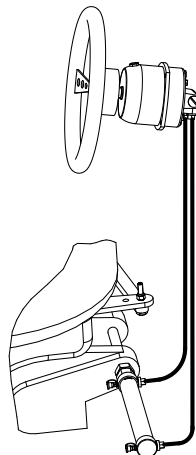

2 motors
2 cylinders
1 pump
1 tie rod

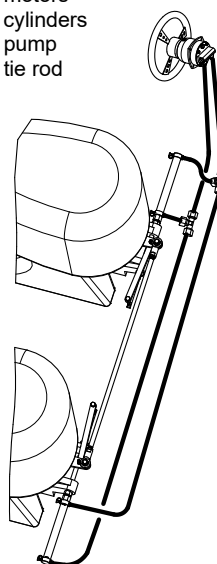

1 motor
1 cylinder
1 pump

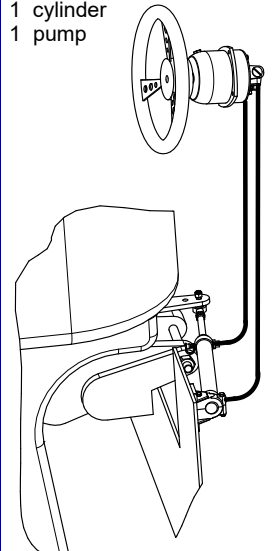

HB 5 TILT PUMPS



This product – the only one of its kind – is the most compact system on the market.

The hydraulic pump has been integrated directly into the tilt mechanism and is fitted with a lock valve.

ORIENTATION RANGE

Possible orientation angle:
-24° to +24° (5 positions).

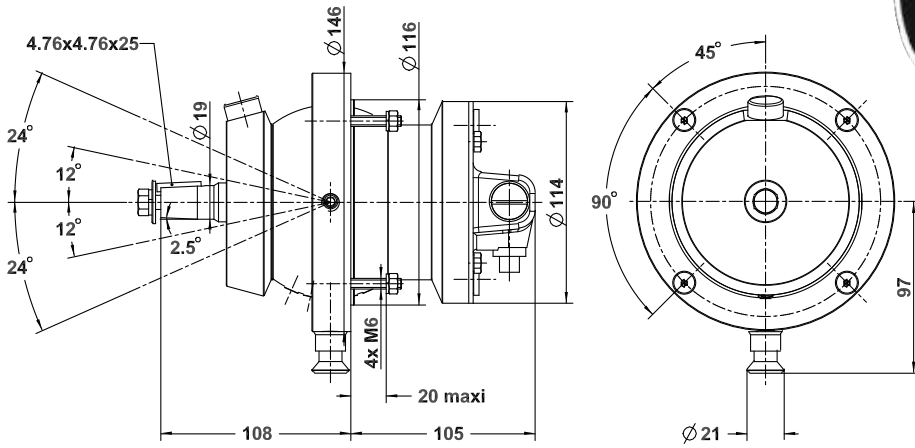

Ref.	Designation	Flow rate
2203658	HB 5 TILT PUMP – 20 CT	20 cc/t
2203559	HB 5 TILT PUMP – 26 CT	26 cc/t
2203659	HB 5 TILT PUMP – 30 CT	30 cc/t
2203669	HB 5 TILT PUMP – 35 CT	35 cc/t
2203670	HB 5 TILT PUMP – 40 CT	40 cc/t
2203695	HB 5 TILT PUMP – 50 CT	50 cc/t



HYDRAULIC STEERING SYSTEMS FOR STERN-DRIVES

HYDRAULIC STEERING SYSTEMS FOR POWER ASSISTED STERN-DRIVES

Cylinder type 28 ST HB AS is fitted directly on the power assisted steering system of the stern-drive motor. No additional mounting kit is required. It is suitable for Volvo, OMC, Mercruiser, Yamaha and others...

The kit for a single steering station consists of:

- 1 pump type 30 HB with lock valve **2200950**
- 1 set of pump fittings **2200021**
- 1 set of cylinder fittings **2200022**
- 1 cylinder type VHM 28 ST HB AS **2200358**
- x metres of Ø 8 mm flexible tube **2200024**

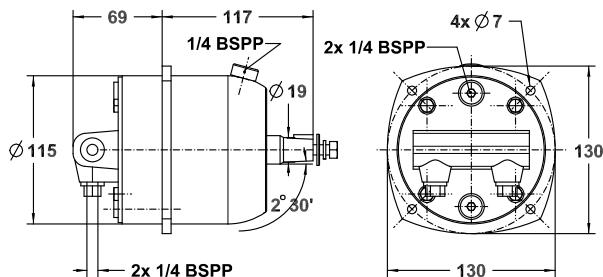

For a double steering station, add the following to the above kit:

- 1 pump type 30 HB with lock valve **2200950**
- 2 sets of pump fittings **2200021**
- 1 set of tees **2200047**
- x metres of Ø 8 mm flexible tube **2200024**

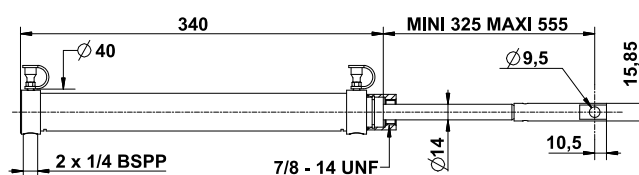

CYLINDERS FOR STERN-DRIVES WITHOUT POWER ASSISTANCE

These cylinders are fitted on in the same way as a cable steering system. Fittings and tubes are the same as for cylinder VHM 28 ST HB AS above (2200358).

Number of turns lock to lock in function of the PUMP / CYLINDER selection	2200948 26 HB-L.V.	2200950 30 HB-L.V.	2201105 35 HB-L.V.	2201107 40 HB-L.V.	TYPE OF MOTOR TYPE OF CYLINDER <i>(Other types on request)</i>
	4	3.6	3	2.6	Up to 175 H.P. VOLVO 2200546 28 ST HB DT
	5	4.5	3.7	3.2	Up to 260 H.P. VOLVO 2200460 32 ST HBV DT
	4.7	4.2	3.5	3	Up to 175 H.P. MERCUISER - OMC 2200344 32 ST HBM DT
	2200948	2200950	2201105	2201107	26 HB with lock valve 30 HB with lock valve 35 HB with lock valve 40 HB with lock valve

HYDRAULIC STEERING SYSTEMS FOR RACE BOATS



SINGLE-ENGINE INSTALLATION

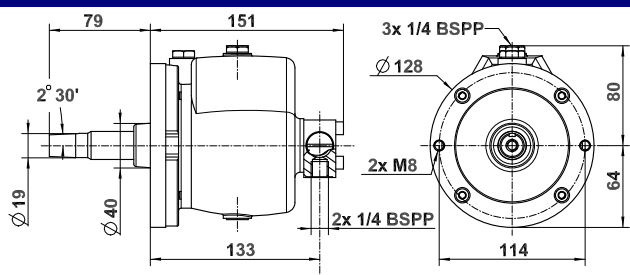

2200073 Pump 40 CT with lock valve **Weight: 3.9 kg**

The steering system will be composed of:

- 1 Pump 40 CT with lock valve **2200073**
- 3 Sets of pump fittings **2200021**
- 1 Distribution block **2210002**
- 2 Sets of cylinder fittings **2200023**
- 2 "Race" cylinders 28 C 158 **2210000**
- or 2 "Race" cylinders 32 ST 20 C 181 **2210007**
- x Metres of Ø8 flexible tube **2200024**

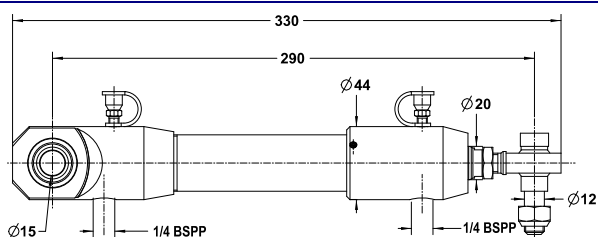

2210000 Race cylinder 28 C 158 **Weight: 1.2 kg**

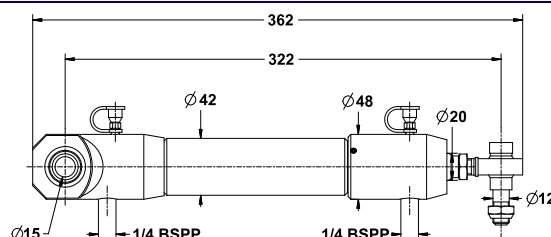

2210007 Race cylinder 32 ST 20 C 181 **Weight: 2.2 kg**

TWIN-ENGINE INSTALLATION

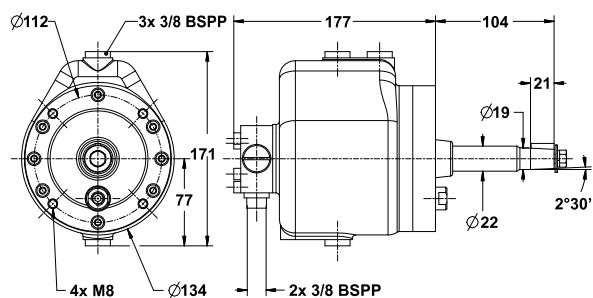

2202068 Pump 30-90 CT with lock valve **Weight: 7.5 kg**

The steering system will be composed of:

- 1 Pump 30-90 CT with lock valve **2202068**
- 1 Distribution block **2210002**
- 2 Sets of cylinder fittings **2200023**
- 2 S/steel cylinders 40 ST 28 C220 **2201976**
- x Metres of Ø8 flexible tube **2200024**
- + Various fittings

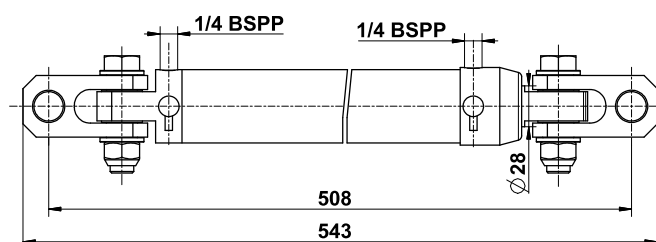

2201976 Race cylinder 40 ST 28 C220 **Weight: 6.4 kg**

2200017
2 litre oil can
for LS hydraulic steering



Photo: Laurent PLASSE / OFFSHORE PASSION

CYLINDERS WITH TILLER FOR OUTBOARD MOTORS

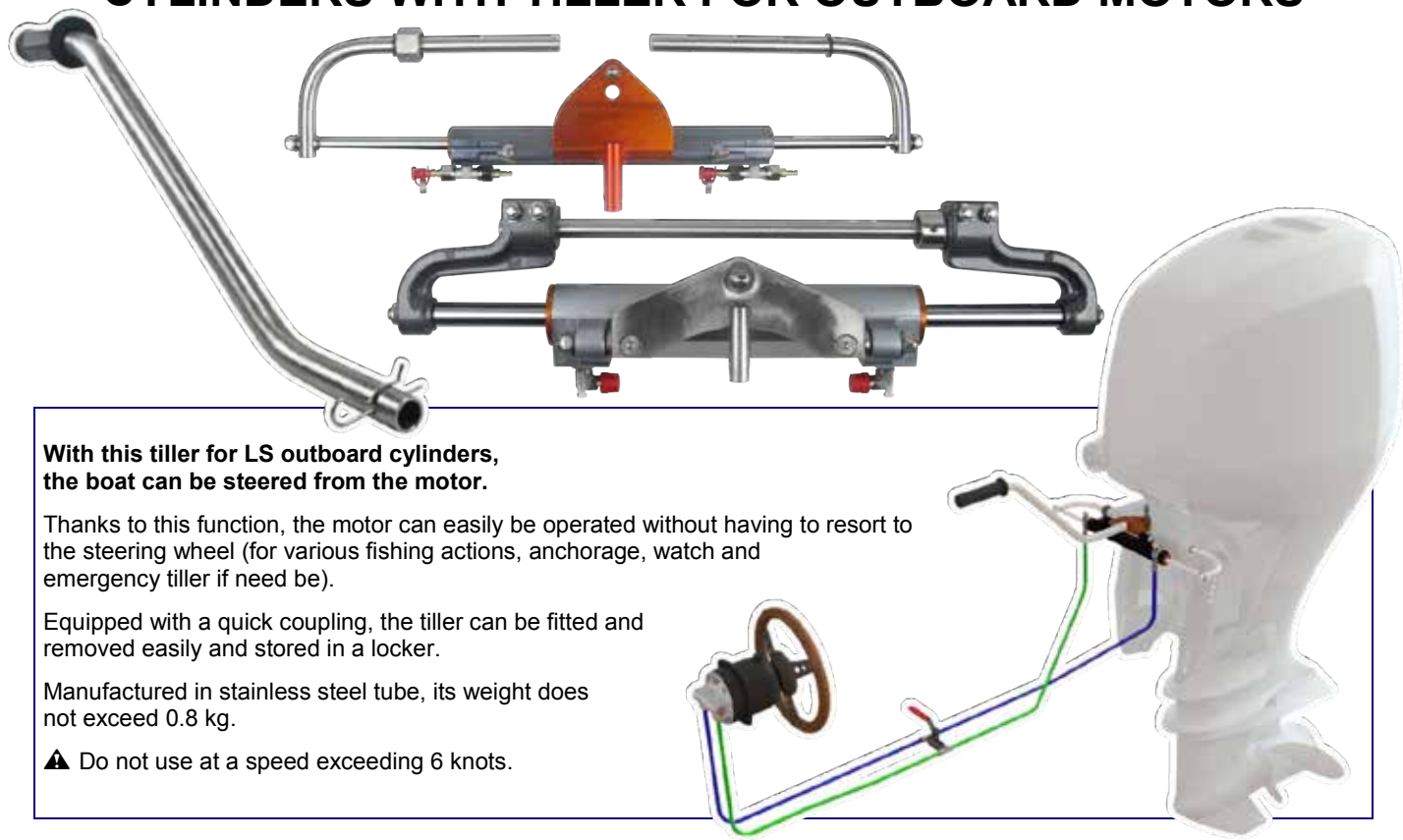

With this tiller for LS outboard cylinders, the boat can be steered from the motor.

Thanks to this function, the motor can easily be operated without having to resort to the steering wheel (for various fishing actions, anchorage, watch and emergency tiller if need be).

Equipped with a quick coupling, the tiller can be fitted and removed easily and stored in a locker.

Manufactured in stainless steel tube, its weight does not exceed 0.8 kg.

⚠ Do not use at a speed exceeding 6 knots.

2203678 Cylinder VHM EX 80 BF

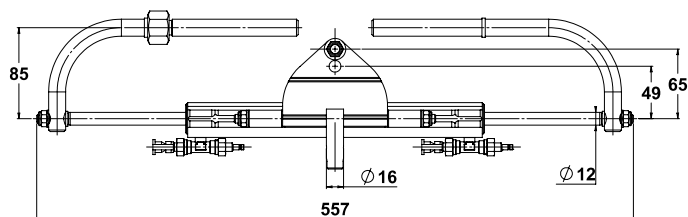

2203575 Cylinder VHM EX 3500 BF

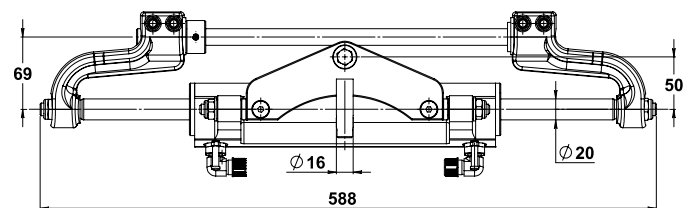

1206402 HB Tiller

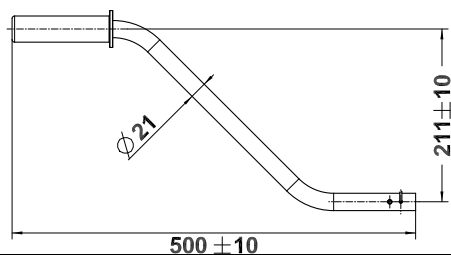

By-Pass Valves

- ① **2200803** By-pass valve for flexible tube TS 6
- ① **2202496** By-pass valve for flexible tube TS 8
- ② **2200027** By-pass valve for flexible tube \varnothing 8 mm



Recommended Pump Model in Function of the Cylinder

	Pump	2200804 20 HB LV 20 cc/t	2200950 30 HB LV 29 cc/t	2201105 35 HB LV 35 cc/t
Cylinder				
VHM EX 80 BF		3.5 turns		
VHM EX 3500 BF			7.5 turns	6.5 turns

1206650 VHM EX 80 BF bracket



1206401 VHM EX 3500 BF bracket



ACCESSORIES FOR OUTBOARD STEERING SYSTEMS

2203853 OB FILLING KIT



2203671 ADAPTATION KIT FOR HONDA MOTORS 115, 135, 150 CV



2203322 SEPARATOR DSC1.0

2203103 SEPARATOR DSC1

Fuel-water separators specifically designed for outboard motors, DSC1.0 and DSC1 come with two Ø8mm and two Ø10mm adjustable fittings, assembly screws and bolts and an instruction manual.

For outboard motors from 4 HP to 45 HP

For outboard motors from 45 HP to 300 HP



NON DISPOSABLE FILTERS



2203947 VHM 80/125 HP SET OF BULLHORNS FOR SUZUKI

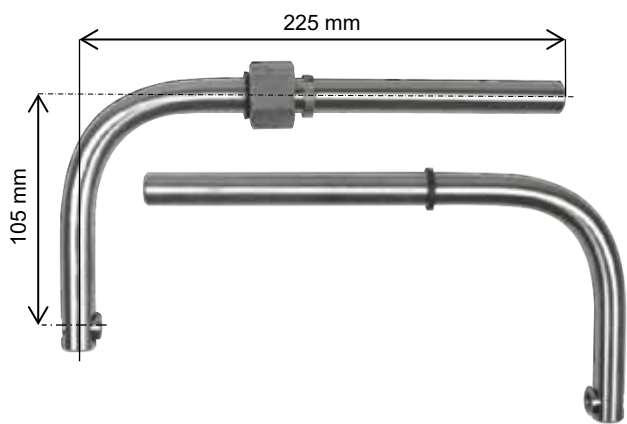

1206946 EQUIPPED GREASE NIPPLE



Can be installed on all LS hydraulic steering systems up to 175 hp and on all types of cable steering.

1207000 CUT BACK BRACKET FOR VHM 125/175/225 HP



2203948 SET OF FITTINGS FOR EVINRUDE E-TEC G2



For the installation of LS pumps and hydraulic hoses on the EVINRUDE E-TEC G2 outboard motor range.

2200017 2 LITRE OIL CAN DEXRON II



For all types of LS hydraulic steering systems.

2201753 BULKHEAD STRAIN RELIEF



Suitable for all LS flexible tubes and all other flexible tubes with an outer diameter of 8 to 12 mm.

2201058 PUMP BEZEL



ACCESSORIES FOR OUTBOARD STEERING SYSTEMS

TIE RODS FOR OUTBOARD MOTORS



2202911 Center distance between motors 450 – 650 mm
2202912 Center distance between motors 650 – 850 mm



2220241(*) Center distance between motors 470 – 710 mm
22202102(*) Center distance between motors 710 – 940 mm



22202103(*) Center distance between motors 580 – 810 mm *To be fitted with 1 VHM EX 350 HP or 1 VHM EX 3500 HP*



22202123(*) Center distance between motors 650 – 880 mm *To be fitted with 2 VHM EX 350 HP or 2 VHM EX 3500 HP*



22203756(*) Center distance between motors 600 – 820 mm *To be fitted with 1 VHM EX 125 / 175 / 225 HP*



22203614(*) Center distance between motors 640 – 850 mm *To be fitted with 2 VHM EX 125 / 175 / 225 HP*

(*)Allow the tilting of one motor independently of the other one

2203593 LS SPEEDY PURGE

Better, Faster and Neater Air Purge

LS SPEEDY PURGE is a tool designed to **fill and purge** air from LS hydraulic steering systems fitted on 5 to 15 metre boats.

LS SPEEDY PURGE connects directly to the 12 volt boat battery with crocodile clips and to the cylinder and pump with 2 x 4 metre clear spiral hoses.

Easily **transportable**, its 4 litre oil contents gives enough autonomy to fill and bleed 2 to 3 steering systems in a row without refilling.

Fill and purge is done neatly **by a single operator in less than 10 mn**, so that SPEEDY PURGE is paid off from the very first steering systems.



2203836 LS Speedy purge – 12V – with 4 m extension hoses

1206948 Set of 2 x 4 m extension hoses

RANGE OF STEERING WHEELS

2200181 Plastic Wheel Ø 320

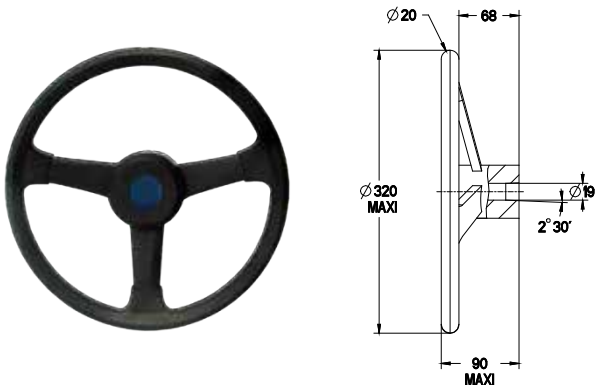

2200182 Imitation Leather/Anodised Alu Ø 320

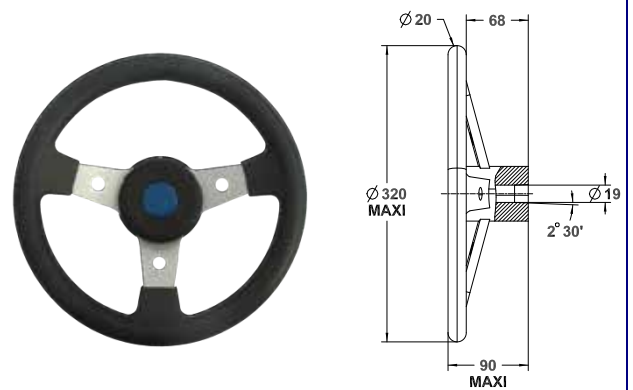

2202462 S/Steel Wheel with knob Ø 275

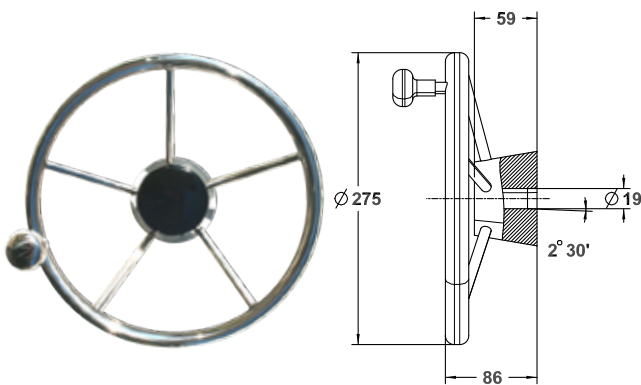

2200985 S/Steel Wheel Ø 350

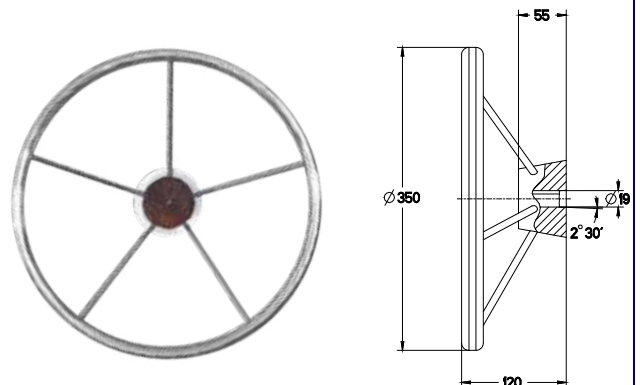

2203377 Covered S/Steel Wheel Ø 360

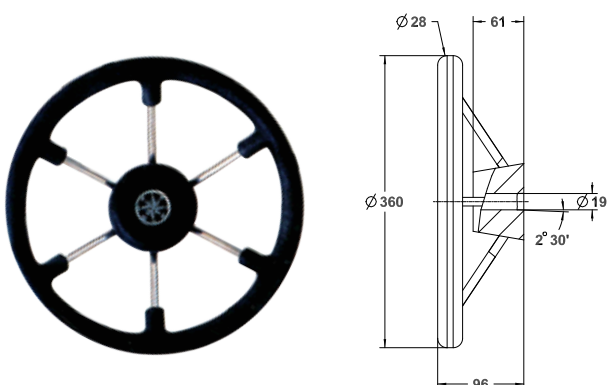

2200986 S/Steel Wheel Ø 400

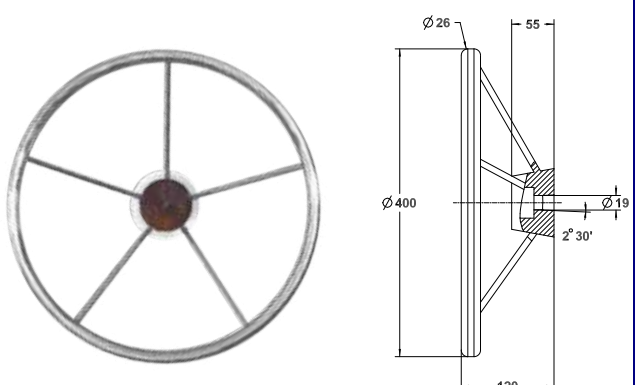

HYDRAULIC FLEXIBLE TUBES

FLEXIBLE TUBES FOR CRIMP CONNECTIONS

Only the sole use of LS flexible tubes in Ø6, Ø8 or Ø10 mm will **guarantee** the global performances and safe use of LS steering systems.

A few references:

- Ø6 Flexible tube - per metre	2200810
- Ø8 Flexible tube - per metre	2200024
- Ø10 Flexible tube - per metre	2200070
- Ø6 Flexible tube - length 8 m	1204267
- Ø6 Flexible tube - length 10 m	1204268
- Ø6 Flexible tube - length 12 m	1204740
- Ø6 Flexible tube - length 25 m	1204985
- Ø6 Flexible tube - length 35 m	1205301
- Ø6 Flexible tube - length 400 m	1205359
- Ø8 Flexible tube - length 10 m	1204825
- Ø8 Flexible tube - length 12 m	1204742
- Ø8 Flexible tube - length 20 m	1205245
- Ø8 Flexible tube - length 35 m	1205300
- Ø8 Flexible tube - length 400 m	1205360













Ø8 FLEXIBLE TUBES WITH PRE-CRIMPED CONNECTIONS

- Flexible tube - length 5 m	1290502
- Flexible tube - length 6 m	1290503
- Flexible tube - length 6.5 m	1290610
- Flexible tube - length 7.5 m	1290504

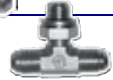

FITTINGS

FOR FLEXIBLE TUBE

Type	Designation	Code for steel	Code for s/steel
 Elbow fittings 90°	1/4 BSPT JIC M. 9/16	2200321	2200309
	3/8 BSPT JIC M. 9/16	2200426	
 Swivel elbow fitt.	1/4 BSPP JIC M. 9/16	1205997	1206365
	JIC M. 9/16 – JIC F 9/16	1205894	1205656
 Straight fittings	1/4 BSPT JIC M. 9/16	2200427	2200447
	1/4 BSPP JIC M. 9/16	2200199	2200448
	3/8 BSPT JIC M. 9/16	2200428	
	3/8 BSPP JIC M. 9/16	2200429	2202039
 Adapters	1/4 BSPT JIC F.T. 9/16	2200430	
	3/8 BSPT JIC F.T. 9/16	2200356	
 Connection fitt.	JIC M. 9/16	2200288	
 Tee fittings	Rotatable 1/4 BSPP 2 x JIC M. 9/16	2200431	
	3/8 BSPT 2 x JIC M. 9/16	2200432	
 Equal tee fittings	JIC M. 9/16	2200433	2202009
 Swivel tee fittings	Rotatable JIC M. 9/16	2201566	
 Straight fittings	JIC M. 9/16 inner diam. 8	2200299	2200449
	JIC M. 9/16 inner diam. 10	2200301	
 Elbow fittings	Inner diam. 8	2200302	
	Inner diam. 10	2200303	
 Connection fitt.	Inner diam. 8	2200373	
	Inner diam. 10	2200434	

GUARANTEE

- 1) The manufacturer guarantees the equipment sold and supplied against any faulty manufacturing or defects whether they are the result of the design, the raw material, the manufacturing or construction under the terms and restrictions indicated below :
 - 2) The guarantee is applicable only if the client has satisfied the general obligations of this contract, in particular, the terms of payment.
 - 3) The guarantee only includes equipment sold by the manufacturer. It does not extend to equipment in which the manufacturer's supply has been installed and, in particular, to the performances of this equipment.
 - 4) When the manufacturer's supplies are installed by the client or a third party into any other equipment, they remain solely responsible for this installation, the selection and suitability of the manufacturer's supplies as the manufacturer's diagrams, designs and proposals are given as an indication only, unless otherwise specified in the order. In particular, the manufacturer does not guarantee components or equipment not sold by him, nor the assembly, adaptation, design or operation of the assembly or parts of the assembly thus created. The manufacturer's supply, as well as the assembly created by the client or a third party, are assumed to be operated under the exclusive control of the client or the third party.
 - 5) The period of the guarantee is eighteen months starting from the date of first use by the original consumer or twenty four months from the date of delivery of the products to the transporter, distributor or wholesaler. The manufacturer has the right to require from the client proof of the commissioning date specified on the guarantee request. This period is neither extended nor interrupted through legal or amicable claims on the part of the client. At the end of this period, the guarantee is terminated without further consideration.
 - 6) The obligation of the guarantee only applies if the client establishes that the defect appeared under normal operating conditions stipulated for this type of supply, or indicated by the manufacturer in writing and during normal operation. It does not apply in case of negligence, faulty maintenance or supervision, operator's responsibility, imprudence, non observance of recommended or operating instructions, or the use of oil of insufficient quality for the equipment. The manufacturer is released from responsibility for any damage caused by loss of oil or leaks. The guarantee also does not apply for any incidents resulting from a case of force majeure or Acts of God, as well as any damage, replacement or repairs exceeding the normal material wear.
 - 7) The guarantee is limited to the repair in the manufacturer's shop at his own cost within the shortest possible time, of the equipment and parts supplied by him, identified as defective by the technical department. These parts must be sent pre-paid. No claim may be made for compensation for any damage such as personal injury, damage to goods other than those concerned in this contract, privation of possession, operating losses, commercial damage or loss of earnings. During the guarantee period, the cost of labor, dismantling and reassembly of the equipment outside the manufacturer's plant, the shipping costs for repaired, replaced or faulty equipment, travelling and accommodation expenses for technicians are the responsibility of the client.
- When the guarantees are given according to the industrial results for a given equipment, these results and the consequences of this undertaking will result in a special agreement between the parties.
- 8) In order to take advantage of this guarantee, the client must notify the manufacturer in writing as soon as possible of the defects attributed to the equipment and provide any proof concerning these defects. He must do his best for the manufacturer to be able to ascertain these defects and to perform corrective actions. The guarantee does not apply if the equipment is not returned to the manufacturer in the state in which it broke down or if it has previously been disassembled, repaired, modified either by a third party, the user or the client. After receiving proper notification of the equipment defect, the manufacturer shall correct this fault as soon as possible, reserving the right, if applicable, to modify all or part of equipment in order to fulfil the obligations.
 - 9) The client agrees that the manufacturer will not be responsible for damage due to the fact that the client has not satisfied any one of the obligations defined above.

see us on the web
www.ls-france.com



Hydraulic steering
Lecomble & Schmitt

PRODUCTS - DISTRIBUTORS - SERVICE & SUPPORT - MANUALS & CATALOGS - COMPANY - CONTACT

Lecomble & Schmitt - Lecomble & Schmitt Company

Contact us

Brief history

At the time of its setting up in the Paris region in 1844, Lecomble & Schmitt was designing and manufacturing volumetric pumps with flow-rate regulation. It was not until 1883 that boosted by 40 years of experience in hydraulics the adventure in the radical industry started in the machines. The company had moved to the Basque Country in the middle south west of France.

Tomorrow, Lecomble & Schmitt is the only French manufacturer to offer hydraulic and mechanical steering systems for pleasure boats, fishing and work crafts.

Since 1999 LE has been a subsidiary of the industrial group Ardenis which is also established in the Basque Country. The activities of the group and its know-how are extended as complementary and include design, precision machining, sheet metal working, plastics technology (injection and thermoforming) and composite moulding.





LECOMBLE & SCHMITT is a French company specialized in the design and manufacture of hydraulic steering systems for boats.

LECOMBLE & SCHMITT offers an extensive product line for all types of pleasure and commercial power boats as well as for yachts.

LECOMBLE & SCHMITT is here to advise you and define with you the most suitable system according to the specificity of your needs.

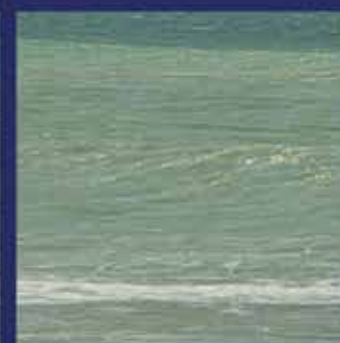

Lecomble & Schmitt

156 Route de Briscous - 64240 URT - France



Sales Department

+33 (0)559 562 411 - commercial@ls-france.com

Technical Department

+33 (0)559 562 646 - commercial2@ls-france.com

Fax : +33 (0)559 569 571

Distributed by