

# HB 5 TILT PUMPS



**This product – the only one of its kind – is the most compact system on the market.**

The hydraulic pump has been integrated directly into the tilt mechanism and is fitted with a lock valve.

## ORIENTATION RANGE

Possible orientation angle:  
-24° to +24° (5 positions).

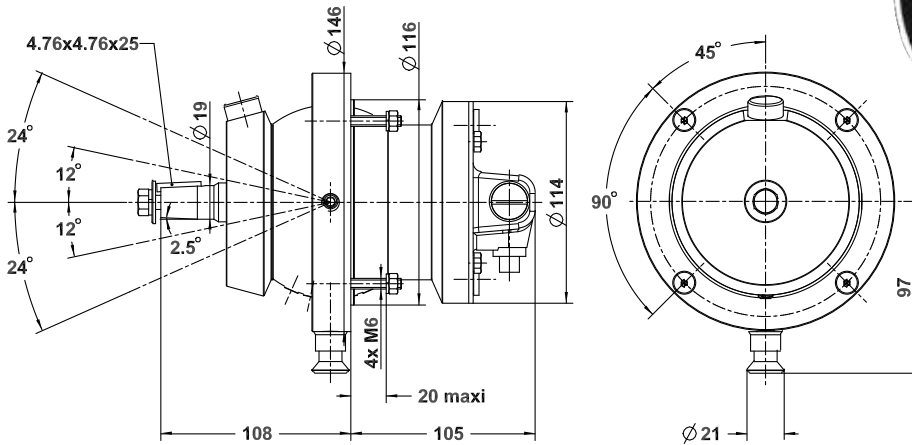

Ref.	Designation	Flow rate
<b>2203658</b>	<b>HB 5 TILT PUMP – 20 CT</b>	<b>20 cc/t</b>
<b>2203559</b>	<b>HB 5 TILT PUMP – 26 CT</b>	<b>26 cc/t</b>
<b>2203659</b>	<b>HB 5 TILT PUMP – 30 CT</b>	<b>30 cc/t</b>
<b>2203669</b>	<b>HB 5 TILT PUMP – 35 CT</b>	<b>35 cc/t</b>
<b>2203670</b>	<b>HB 5 TILT PUMP – 40 CT</b>	<b>40 cc/t</b>
<b>2203695</b>	<b>HB 5 TILT PUMP – 50 CT</b>	<b>50 cc/t</b>

