

Installation Guide

For DC Electric Thruster Models
SE50



SLEIPNER AS

P.O. Box 519

N-1612 Fredrikstad

Norway

www.sleipnergroun.com

DOCUMENT ID: 4319

REVISION: 18

DATE: 2022

LANGUAGE: EN

MI

Contents

Installation Manual

Responsibility of the installer.....	3
Thruster Measurements	4
Thruster Specifications	5
Technical Specifications	5
Positioning of the tunnel / thruster	6
Tunnel Length.....	7
Tunnel installation in sail boats.....	8
Water Deflection	9
Tunnel ends	10
Tunnel installation.....	11 - 12
Stern tunnel installation	13
Gear Leg & Motor Bracket Installation.....	14
Propeller Installation	15
Motor Installation	16
Thruster Electrical Installation	17
Electrical Specifications	18
Technical Wiring Diagram	19
Control Panel Cable Installation	20
Visual Wiring Diagram	21
Control Panel Installation	22
Pre-delivery Checklist	23
Service and Support.....	24
Product Spare Parts and Additional Resources.....	24
Warranty Statement.....	24

Products

SE50/140S-12V - SE50 Tunnel thruster, 12V

SE50/140S-24V - SE50 Tunnel thruster, 24V



Sleipner Motor AS
P.O. Box 519, Arne Svendsensgt. 6-8
N-1612 Fredrikstad, Norway

MC_0020

Failure to follow the considerations and precautions can cause serious injury, damage and will render all warranties given by Sleipner Motor as VOID.

MC_0411

Responsibility of the Installer

MC_0038

The installer must read this document to ensure necessary familiarity with the product before installation.

Instructions in this document cannot be guaranteed to comply with all international and national regulations. It is the responsibility of the installer to follow all applicable international and national regulations when installing Sleipner products.

The recommendations given in this document are guidelines ONLY, and Sleipner strongly recommends that advice is obtained from a person familiar with the particular vessel and applicable regulations.

This document contains general installation instructions intended to support experienced installers. If you are not skilled in this type of work, please contact professional installers for assistance.

If required by local regulation, electrical work must be done by a licensed professional.

Appropriate health and safety procedures must be followed during installation.

Faulty installation of Sleipner products will render all warranties given by Sleipner Motor AS.

For thruster systems

MC_0425

- Do not install the thruster in a position where you need to cut a stiffener/ stringer/ support that may jeopardise the hull integrity without checking with the boat builder this can be done safely.
- We advise painting the gear house and propellers with anti-fouling. **(NB: Do not paint the anodes, sealing, rubber fittings or propeller shafts)**
- There is only room for a thin coat of primer and two layers of anti-fouling between the tunnel and the props.
- Never run the thruster out of water.
- The electric/ hydraulic motor must be handled with care. Do not place down the thruster on the motor drive shaft or gear leg if attached.

For electric motor thrusters

MC_0031

- The thruster must NOT be installed in compartments that require ignition proof electric equipment. If necessary, make a separate compartment. **(NB: Ignition Protected systems are tested to be installed in areas with possible explosive gases in accordance with ISO 8846)**
- When installing the thruster electric motor in small compartments, ensure the compartment is well ventilated to allow for cooling of the electro motor.
- If the height of the room you are installing the thruster is limited, the thruster can be installed horizontally or at any angle in-between.
 - If the electro motor is positioned more than 30 degrees off vertical, it must be supported separately.
 - Beware of keeping installation within advised measurements. No part of the propeller or gear house must be outside the tunnel.
- The electro motor, components and cables must be mounted so they remain dry at all times.
- We advise painting the gear house and propellers with anti-fouling. **(NB: Do not paint the anodes, sealing, rubber fittings or propeller shafts)**
- Do not finish the inside of the tunnel with a layer of gel-coat/ topcoat or similar. There is only room for a thin coat of primer and two layers of anti-fouling between the tunnel and the props.
- Don't install the electric motor close to easily flammable objects or equipment as it will reach over 100°C before the temperature switch is activated.
- Do not store items close to the thruster motor. Any loose items near the thruster motor is a potential fire hazard and can cause undesired short-circuiting.
- Do not lift it by internal cable connections, main terminals.
- The thruster power supply circuit must include the recommended sized fuse and a battery isolation switch.

For DC electric motors

MC_0426

- The electro motor will generate some carbon dust so any storage compartments must be separated from the thruster to prevent nearby items becoming dusty/ dirty. **(NB: IP version motors generate dust but are enclosed.)**

Measurement code	Measurement description	*50 12v		*50 24v	
		mm	inch	mm	inch
ID	Internal tunnel diameter	140	5,51	140	5,51
H	Motor Height	264	10,39	264	10,39
W	Width	200	7,87	200	7,87
L	Length	208	8,19	208	8,19
WD	Water Depth	140	5,51	140	5,51
TL	Minimum tunnel length	124	4,88	124	4,88
TL (recommended)	Recommended tunnel length	152	5,98	152	5,98
T (min)	Minimum tunnel wall thickness	5	0,20	5	0,20
T (max)	Maximum tunnel wall thickness	7	0,28	7	0,28

*Valid for SE & SEP

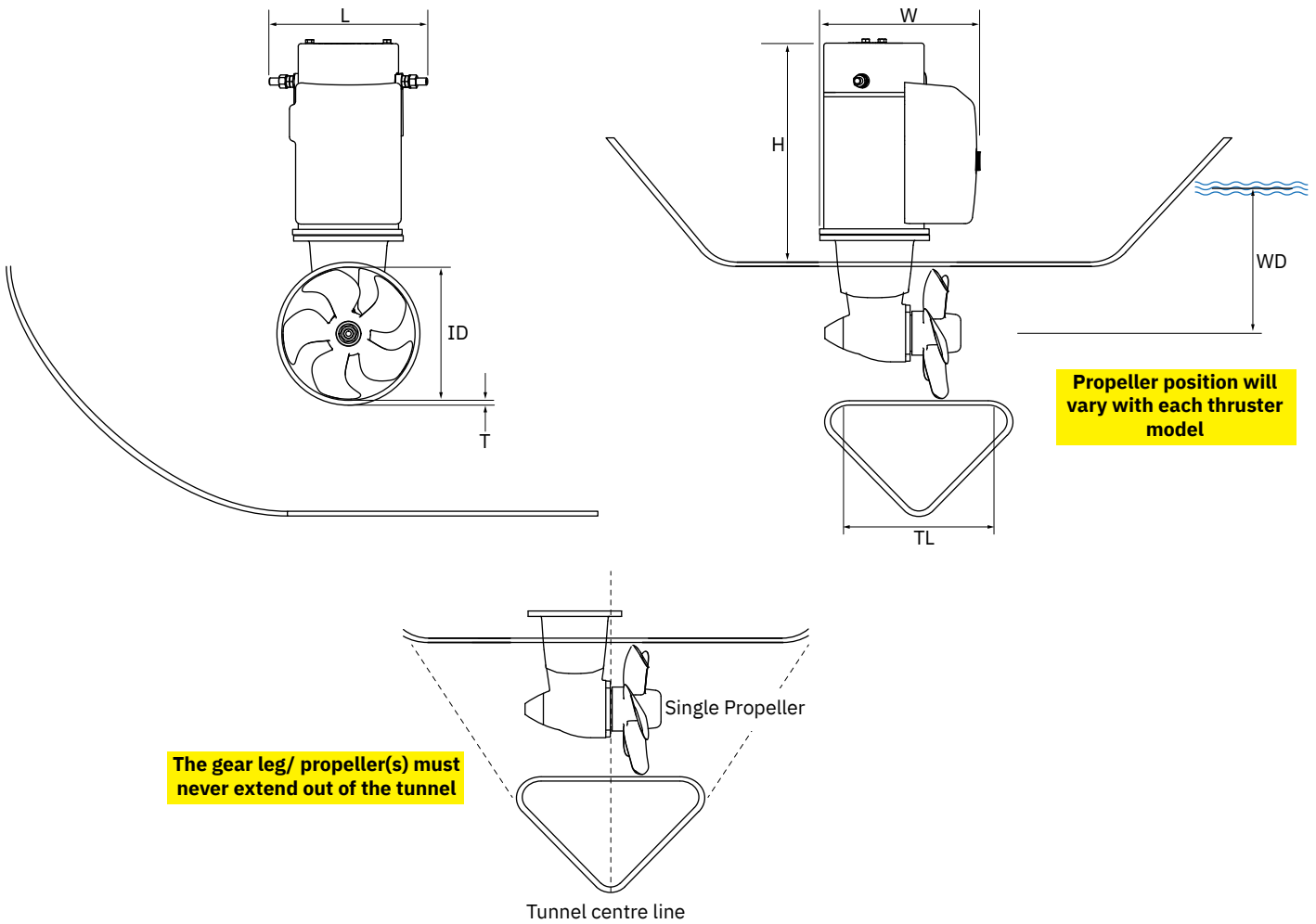

Description	* 50
Available DC System (v)	12v & 24v
Thrust 12v or 24v (kg * lbs)	62 kg * 136 lbs
Thrust 10.5v or 21v (kg * lbs)	40 kg * 110 lbs
Typical Boat Size (m * ft)	8m - 11m * 27ft - 37ft
Propulsion System	Single
Power (kw * Hp)	2.4kw * 3.2hp
Weight (kg * lbs)	15kg * 33lbs

*Valid for SE / SE IP & SEP / SEP IP

Technical Specifications

- Motor:** Custom made reversible DC-motor.
- Gear house:** Seawater resistant bronze. Ball-bearing at propeller shaft and a combination of ball bearing and slide bearing at drive shaft. (Pre-filled and sealed for life)
- Motor bracket:** Glass fibre reinforced composite material. Brass thread inserts.
- Tunnel:** Cross spun with rowing G.R.P tunnel
Steel & aluminium tunnels available at request.
- Propeller:** 5-blade skewback "Q-prop" propeller, fibreglass reinforced composite.
- Batteries:** Minimum recommended battery capacity (cold crank capacity by DIN/SAE standard)
Contact a battery supplier for more information.
- Max. Use:** 2 - 3 min. duty cycle at 20°C
- Safety features:**
- Electronic time-lapse device protects against sudden change of drive direction.
 - The electric thermal cut-off switch in electro motor protects against overheating (auto-reset when electro motor cools down).
 - Flexible coupling between electro-motor and drive shaft protects electro motor and gear system if propeller jams.
 - Original Sleipner panels shut off automatically 6 minutes after last use. This interval can be adjusted in 5 min steps up to 60 minutes or turned off completely.
 - Original Sleipner panels use child-safe double ON buttons.
 - An integrated microprocessor monitors solenoids, reduce wear and risk of solenoid lock-in.
 - Auto-stop of the thruster occurs when an undesirable solenoid lock-in occurs or when continuous operation cut-off timer exceeds 3 minutes.

Aim to install the thruster as far forward as possible (1)

Due to the leverage effect around the boats' pivot point. The distance difference from the boat pivots' point to the thruster will determine the amount of real rotation power for the boat.

Aim to install the thruster as deep as possible under the waterline (2)

Deeper installations prevent air from being sucked into the tunnel from the surface, resulting in reduced thrust performance and increase noise levels during operation. Deeper installations increase water pressure for maximum efficiency from the thruster.

The centre of the tunnel should be a minimum of 1 x the tunnel diameter below the waterline. The installer must make evaluations based on thruster performance, boat type and operating conditions. As a general recommendation, the position of the tunnel should not be a minimum of 1/4 of the diameter of the tunnel from the boat keel. **(NB: This can be overlooked depending on the installation methods defined in this manual.)**

1

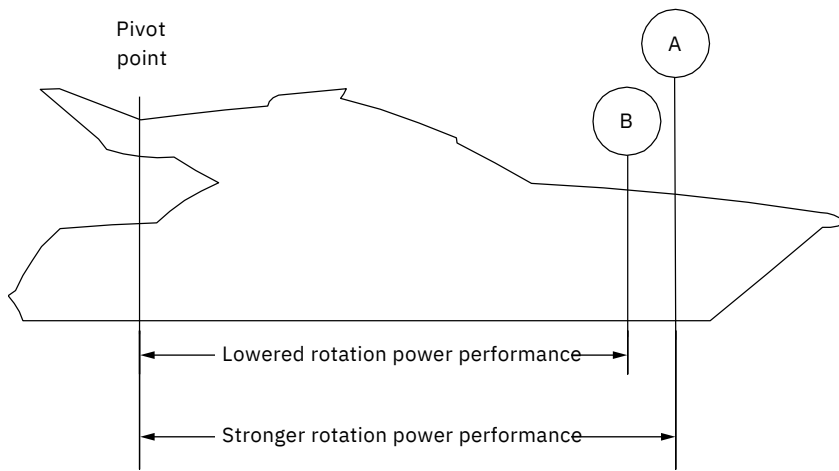

2

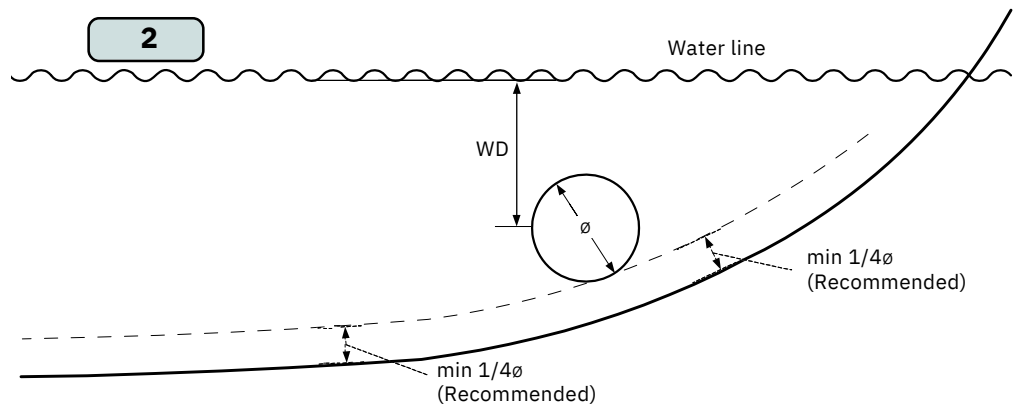

MG_0001

Optimal tunnel length

Achieving the correct tunnel length depends on many factors from the hull type, operation and environmental conditions.

Tunnels should avoid being longer than 4 x the tunnel diameter as this will reduce thruster performance. **(NB: Installing long length tunnels can flex/bend over time and may require additional support. Consult with a naval architect.)**

1. Do not allow the variable length of the tunnel walls to vary in length excessively.
EG. The top tunnel wall is x 4 longer than the bottom wall.
2. If the tunnel is too long, the friction inside will reduce the water speed and thereby the thrust.
3. If the tunnel is too short (typically only in the bottom section of the tunnel) cavitation problems can occur as water flow will not be able to "straighten" itself before reaching the propeller. This cavitation will reduce performance and increase noise during operation.

Thruster within the tunnel

It is important the propellers and the lower unit/ gear leg must be entirely inside the thruster tunnel. Propellers that protrude from the tunnel will not perform as intended.

4. Standard Use

Tunnel length must be long enough to ensure the propellers are not extruding the tunnel.

5. Flat Bottom Hull

Tunnel lengths must be longer than the standard measurement outlined within the manual to ensure a circular vacuum is not created between the thruster and the bottom of the boat.

6. High-Speed Boats

Tunnel lengths must be increased to protect the propeller from damage when crashing against the water surface during high-speed cruising. **(NB: This can include the length of a spoiler)**

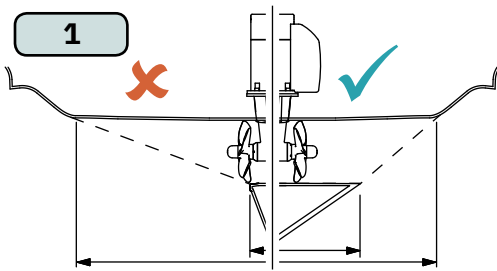

Do not allow the variable length of the tunnel walls to vary in length excessively.
EG. the top tunnel wall is x 4 longer than the bottom wall.

3

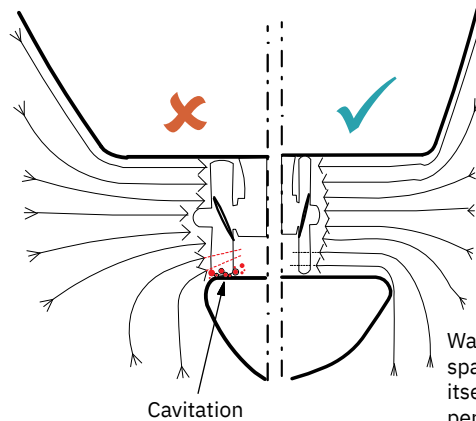

Water flow must have space to "straighten" itself for best performance.

2

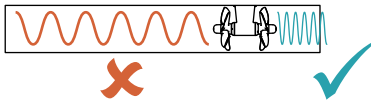

4 STANDARD USE

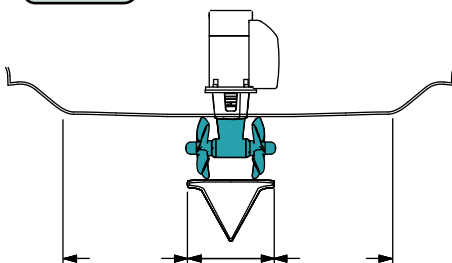

The gear leg/ propeller(s) must never extend out of the tunnel

5 FLAT BOTTOM HULL

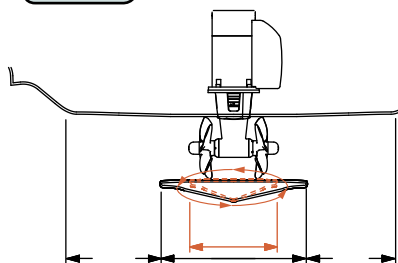

Increase tunnel length to prevent a circular water vacuum cavity between the propeller and the hull of the boat.

6 HIGH-SPEED OPERATION

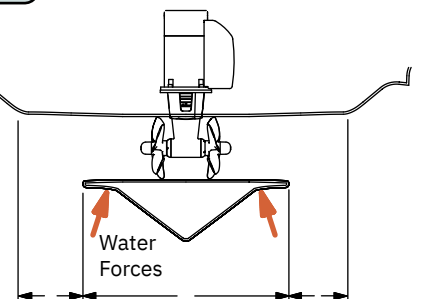

Increase tunnel length to protect the propeller from water forces when high-speed cruising.

MG_0048

Some sail boats have a flat bottom and shallow draft in the bow section. This can make installing the thruster as far forward from the boats main pivot point difficult. **(Fig. 1).**

However, it is possible to install a tunnel thruster in most sail boats, even when the hull does not directly support the fitting of a tunnel.

Instead fit the tunnel halfway into the underneath section of the existing hull. Strengthen it with a deflector/ spoiler directing the water flow around the tunnel. This will allow installation of the thruster in the proper position on the boat, maintaining the reliability and space advantages of the tunnel thruster.

This installation is being used by some of the world's largest sail boat builders and has proven to give little to no speed loss during normal cruising. This can also be an installation method for flat bottomed barges to avoid extremely long tunnels and large oval tunnel openings in the hull.

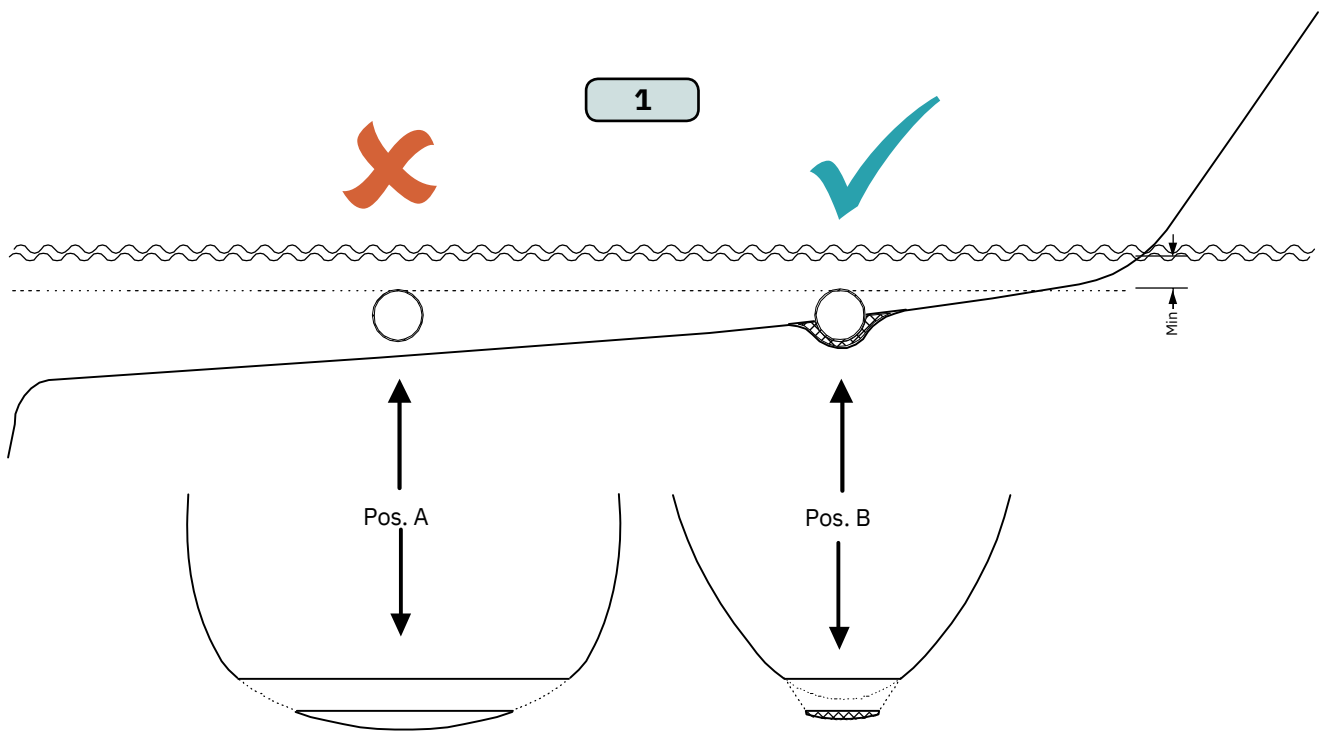

MG_0004

1. A possible problem in sail boats or fast powerboats is that a non-rounded surface can generate drag from the back face of the tunnel, as it creates a "flat" area facing the flow of water.

This problem can be solved in two different ways, depending on what is possible or easier to perform.

2. The best solution which generally reduces the most drag is to make a recess in the hull at the back of the tunnel. As the back face is removed water can flow freely past the tunnel entry. The depth and shape of this recess will depend on the boat and the angle facing up/ down aft of the tunnel insert. Normally it is angled slightly down because of the water flow on this area.
3. Making a deflector/ spoiler in front and underneath the tunnel can also reduce damage to the thruster and drag. The deflector/ spoiler will push the water flow out from the hull so water can pass by the back face of the tunnel. The shape and size of this deflector/ spoiler will depend on the hull shape. The easiest way of making the deflector/ spoiler is to retain a part of the lower forward area of the tunnel while installing the tube. Use this area as support to mould a soft curve/spoiler shape from the hull.
4. The thruster propeller can spin (passively) producing noise while sailing or cruising as water is forced through the tunnel. Water-flow directed through the tunnel at high speeds, during turning or as the boat bumps waves while underway can also damage the thruster.

(NB: As a rule, you should not see the back face of the tunnel when standing directly in front of the boat looking aft.)

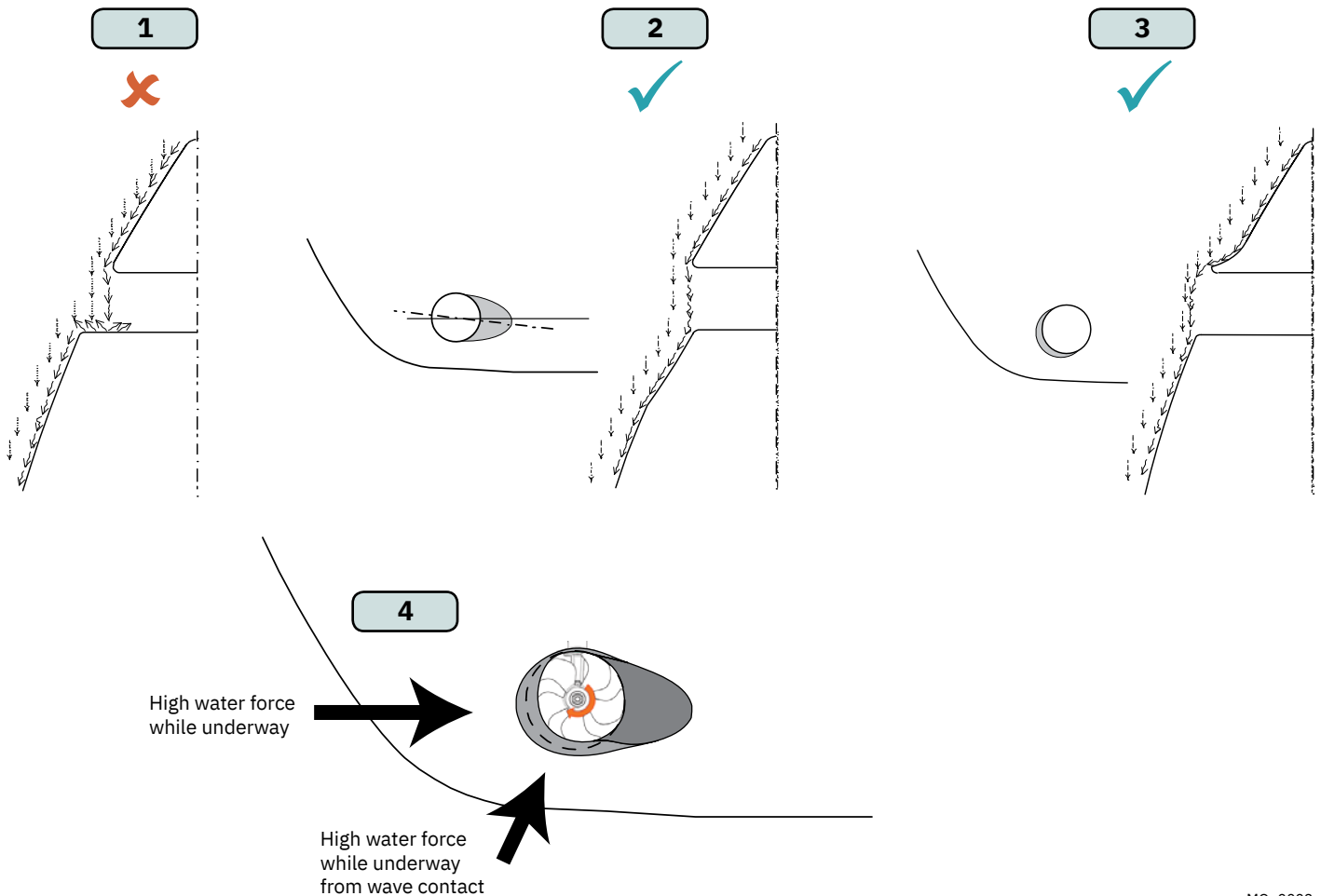

Rounded tunnel ends will maximise thrust and minimise noise and cavitation.

For best performance round the tunnel connection to the hull-side as much as possible. The minimum rounding has a radius of 10% of the diameter of the tunnel.

Significant advantages of a rounded tunnel over a sharp tunnel to hull connections are:

1. A rounded tunnel end will prevent the creation of turbulence/ cavitation created from a sharp tunnel end when water passes by the tunnel.
 - The turbulence/ cavitation will block the outer area of the tunnel and thereby reduces the effective tunnel diameter and thrust.
 - Turbulence/ cavitation on the propeller will lessen the thrusters performance and create excess noise.
2. For steel/ aluminium hulls angled tunnel ends also offer similar performance as a rounded connection.
3. A rounded tunnel end makes the thruster draw water from along the hull-side, creating a vacuum that will suck the boat sideways and thereby give additional thrust.
 - With a sharp tunnel end, the thruster will be unable to take water from along the hull-side, and you will not gain the desired vacuum and additional thrust. This "free" extra thrust in optimal installations be 30 - 40% of the total thrust.

(NB: A Side-power thruster propeller does not produce cavitation at working speed. Therefore, any cavitation and cavitation noise in the tunnel will be caused during improper tunnel installation.)



IMPORTANT

We recommend that a professional does the fibreglass, steel or aluminium fitting of the tunnel. These instructions are only general instructions and do not explain in any way the details of fibreglass work. Problems caused by faulty installation of the tunnel, are the installers full responsibility.

1. Find the position in the boat considering the information earlier in this manual and the applicable measurements for the thruster model you are installing. Mark the centre of the tunnel on both sides of the hull. Drill a hole horizontally at these marks.
2. Mark the circle for the tunnel opening (outside diameter of the tunnel) and cut the hole.
3. Grind off the gel coat to the "real fibreglass" area 12cm around the hole on both inside and outside the hull to cast the tunnel to the hull (**Fig. 3**).
4. Insert the tunnel and mark its shape to fit the hull. (**NB: if you are installing with a deflector/ spoiler, leave a part of the tunnel in the front and underside of the tunnel that will cover the back face.**)
5. Cut the tunnel ends to the desired shape and lightly sand its surface. Clean the area with acetone or similar where you are going to apply fibreglass. (**NB: Do not cast or add fibreglass to the area were the thruster will be placed.**)
6. Cast the tunnel to the inside of the hull, use at least eight layers of 300g fibreglass and resin, preferably alternating mat and rowing types of fibreglass. To round the tunnel ends to a 10% radius make further layers inside to preserve the desired hull thickness.

(**NB: Ensure gaps between the tunnel and the hull are completely filled with resin/ fibreglass. In areas where you can not access to make layers of resin/ fibreglass, a resin/ fibreglass mixture must be used in that area.**)

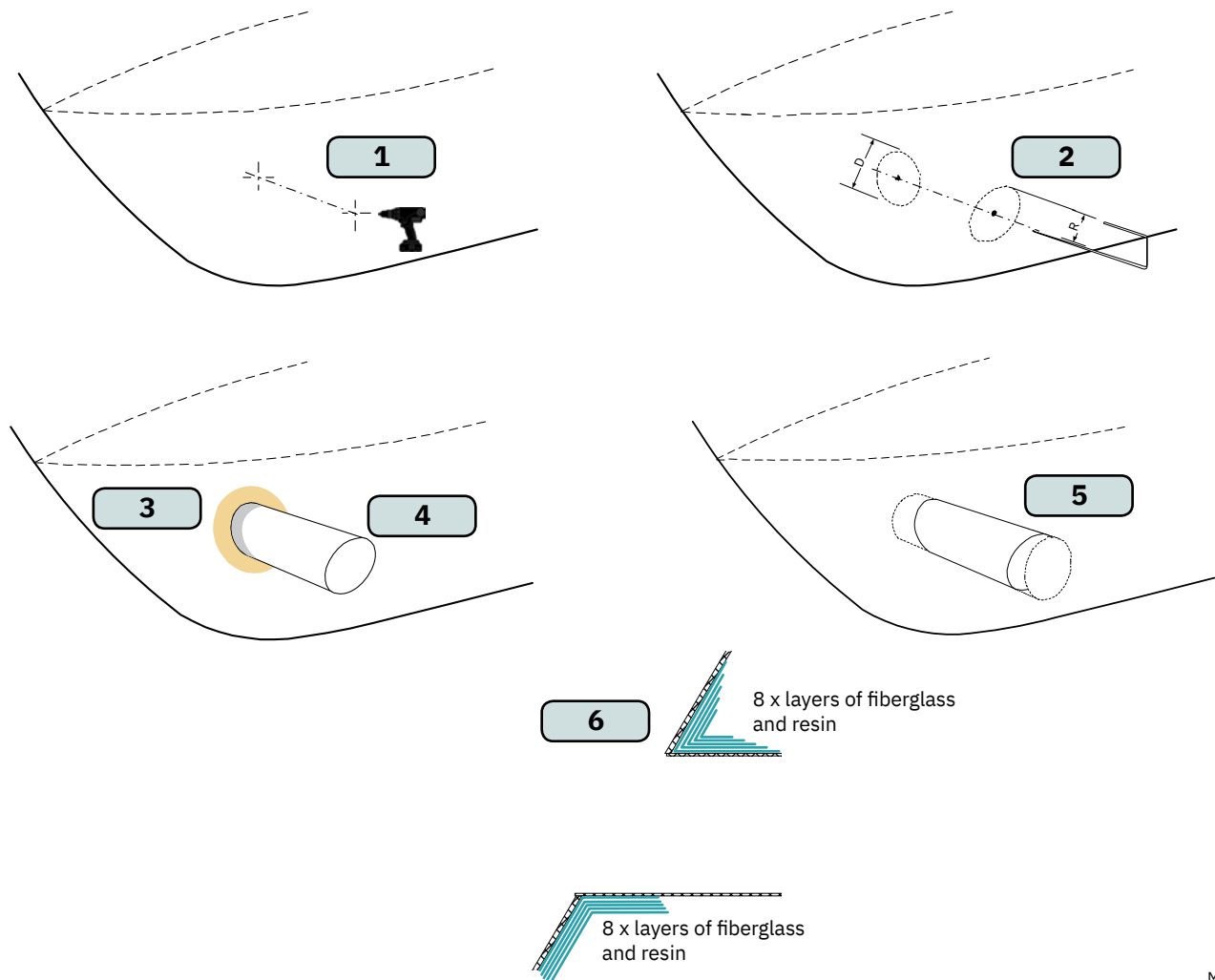

With tunnel installed and cast.

1. Round the edges with a radius of 10% of the tunnel diameter.
2. For steel/ aluminium hulls make a slope with a length of 10-15% of the tunnel diameter.
(NB: If this is not possible, round the tunnel end as much as possible.)
3. Additionally cast two layers on the outside of the tunnel/ hull in a 10cm area
4. Follow the same method if making the deflector/ spoiler.

You must apply gel coat to areas you have grounded/ moulded to make waterproof. These areas allow water access to the hull which is typically not waterproof without these applications outside. **(NB: All original Side-Power tunnels are fully waterproof when delivered except in the areas where you have cut and bonded it to the hull.)**

IMPORTANT
 Avoid all casting where the motor-bracket is to be placed, as this will cause misfit and possible failure to the gear house.

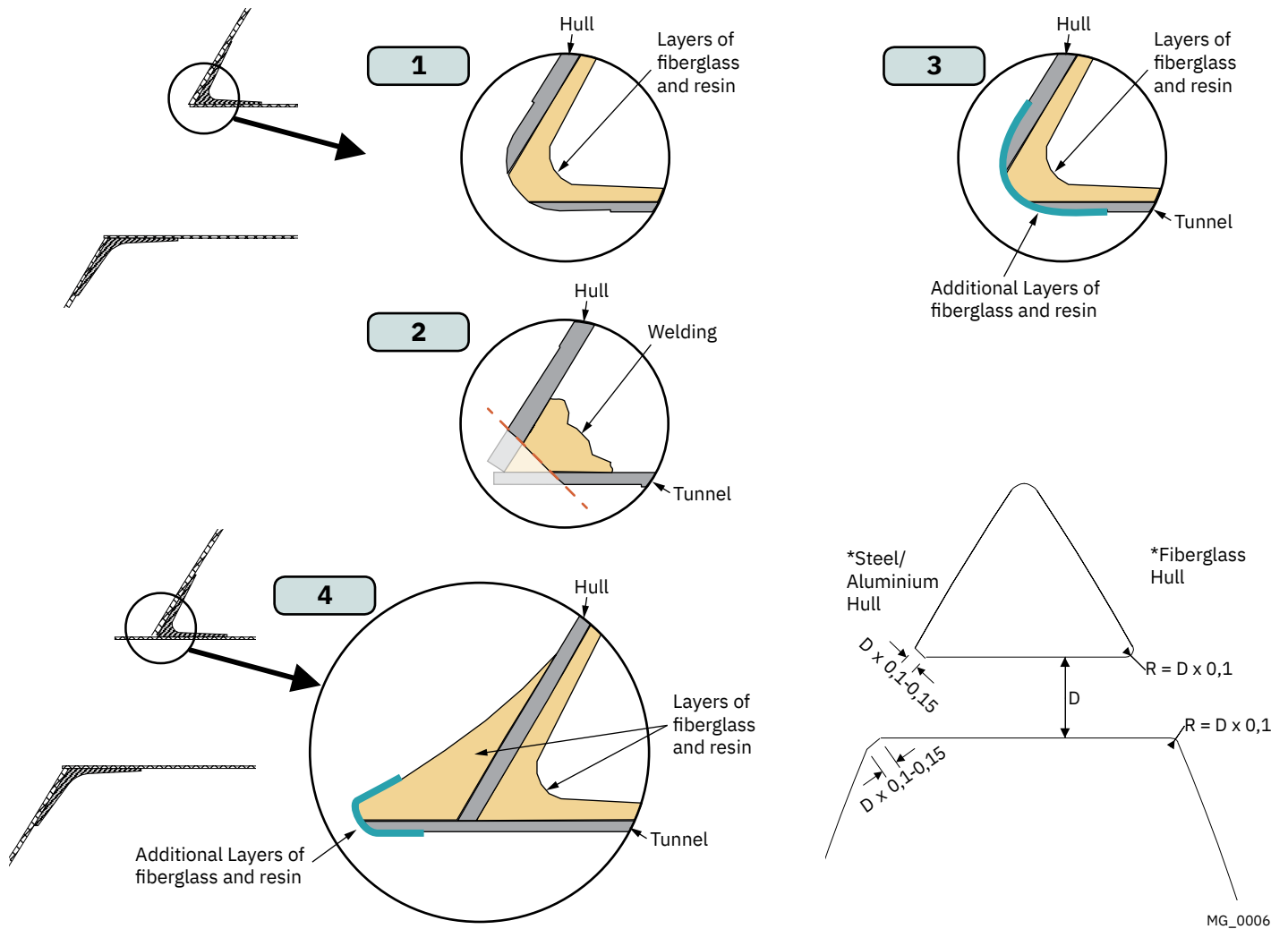

For **Stern Thruster** installation please refer to the supplied manual in your Sleipner product delivery

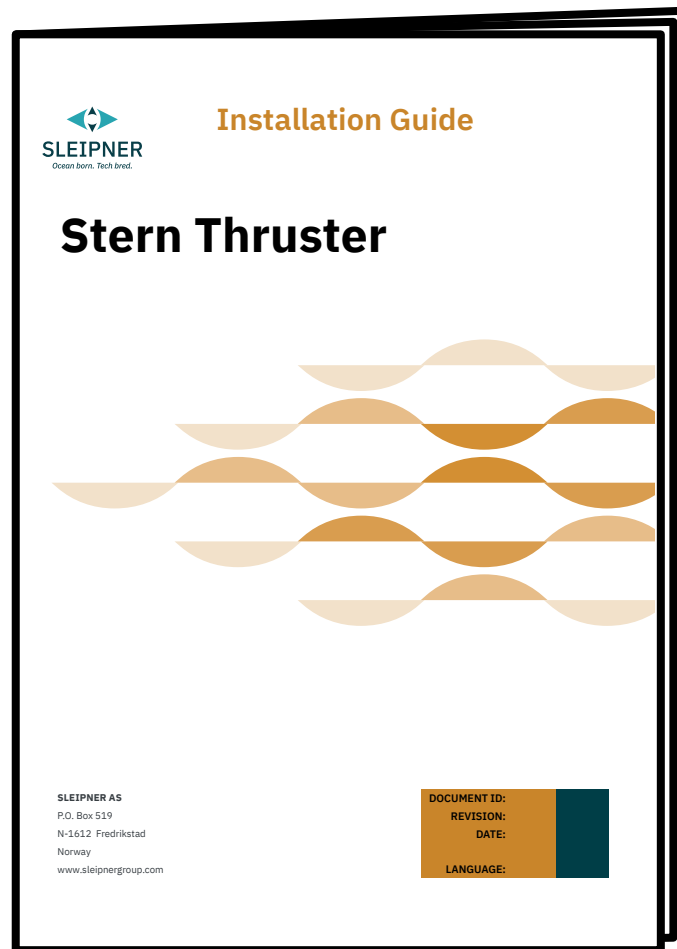

! Please refer to the graphic for special considerations relating to your model !

1. Mark the tunnel centreline and the boat's centreline. **(NB: Install the gear leg and propeller as shown above for the thrust direction to correspond with the control panel.)**
2. Use the gasket or template (recommended) to mark the hole centres and double-check the measurements. One hole **MUST** be placed using the boat centreline as shown above. **(NB: All holes must be in-line with the tunnels' centreline for correct installation, clearance between the propeller and the tunnel is minimal.)**
3. Smooth the surface of the tunnel. A rough surface will cause possible failure/ movement of the gear leg. The motor bracket must rest steadily on the tunnel.
4. Drill the main centre hole followed by the two screw-holes.
5. Place the gear leg (without the propeller) with the gasket on inside the tunnel. Place the propeller on the gear leg to ensure it is centred and rotates freely with the same clearance from each blade to the tunnel wall. Place top motor bracket to measure the drive shaft has come through the motor bracket at the correct height. Remove the gear leg and propeller for final installation.
6. Apply appropriate sealant to both sides of the gasket and place on the gear leg. Place the gear leg in the tunnel (without the propeller).
7. Install the top motor bracket and gear leg gently together. Use appropriate sealant to ensure that no leakages occur. **(NB: See your sealant data sheet for the correct application process.)**
8. Fasten the gear leg and the motor bracket with the bolts provided. Tighten to torque as shown above.

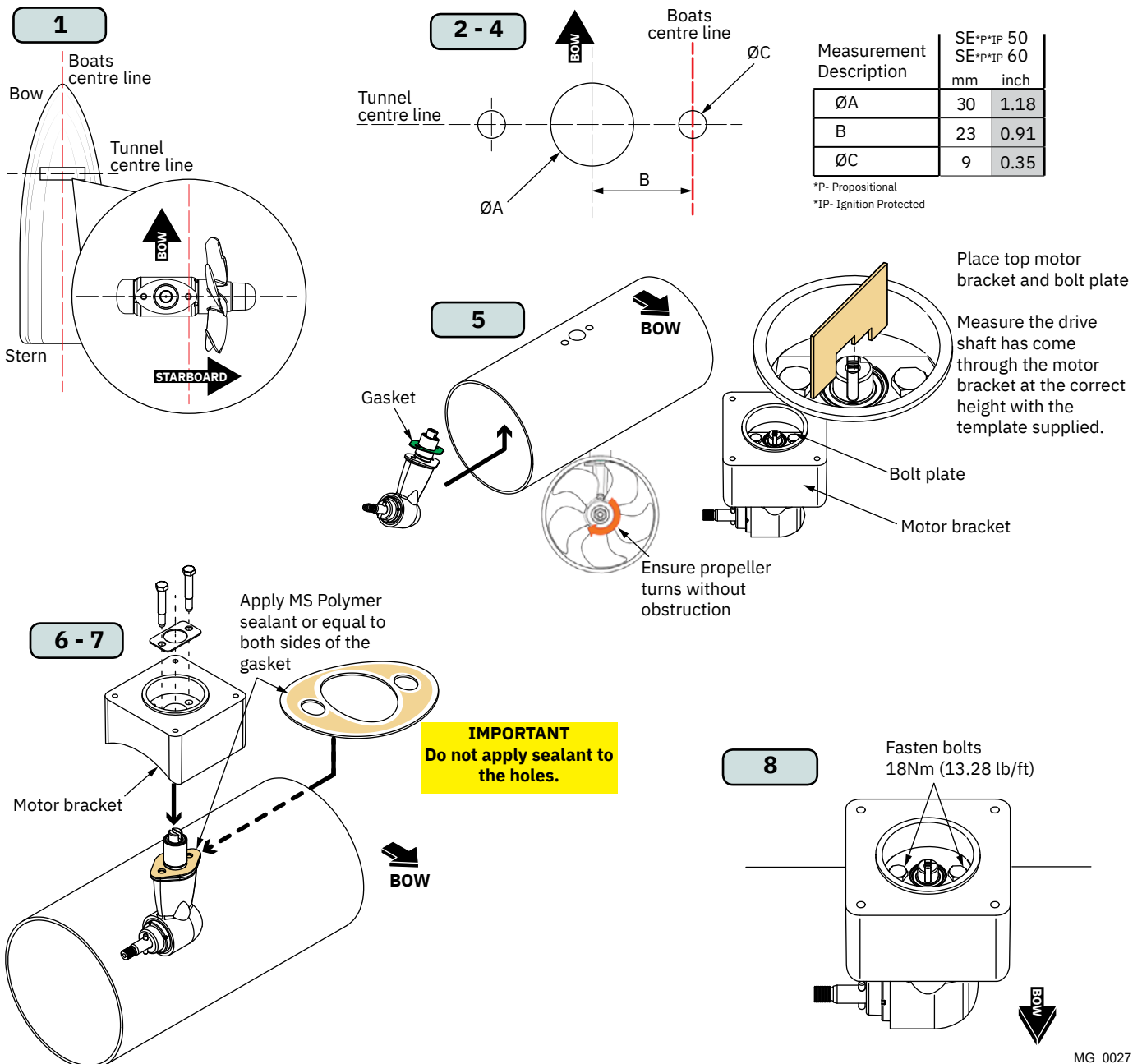

! Please refer to the graphic for special considerations relating to your model !

1. Centre the drive pin and Insert the propeller onto the shaft spline. Rotate the propeller until the drive pin aligns with the internal slot in the propeller.
2. Insert the washer to the end of the shaft spline. Tighten with the propeller lock-nut.
3. Apply anti fouling to the gear leg and propeller. Do not apply anti fouling to any rubber elements of the gear leg or anodes.

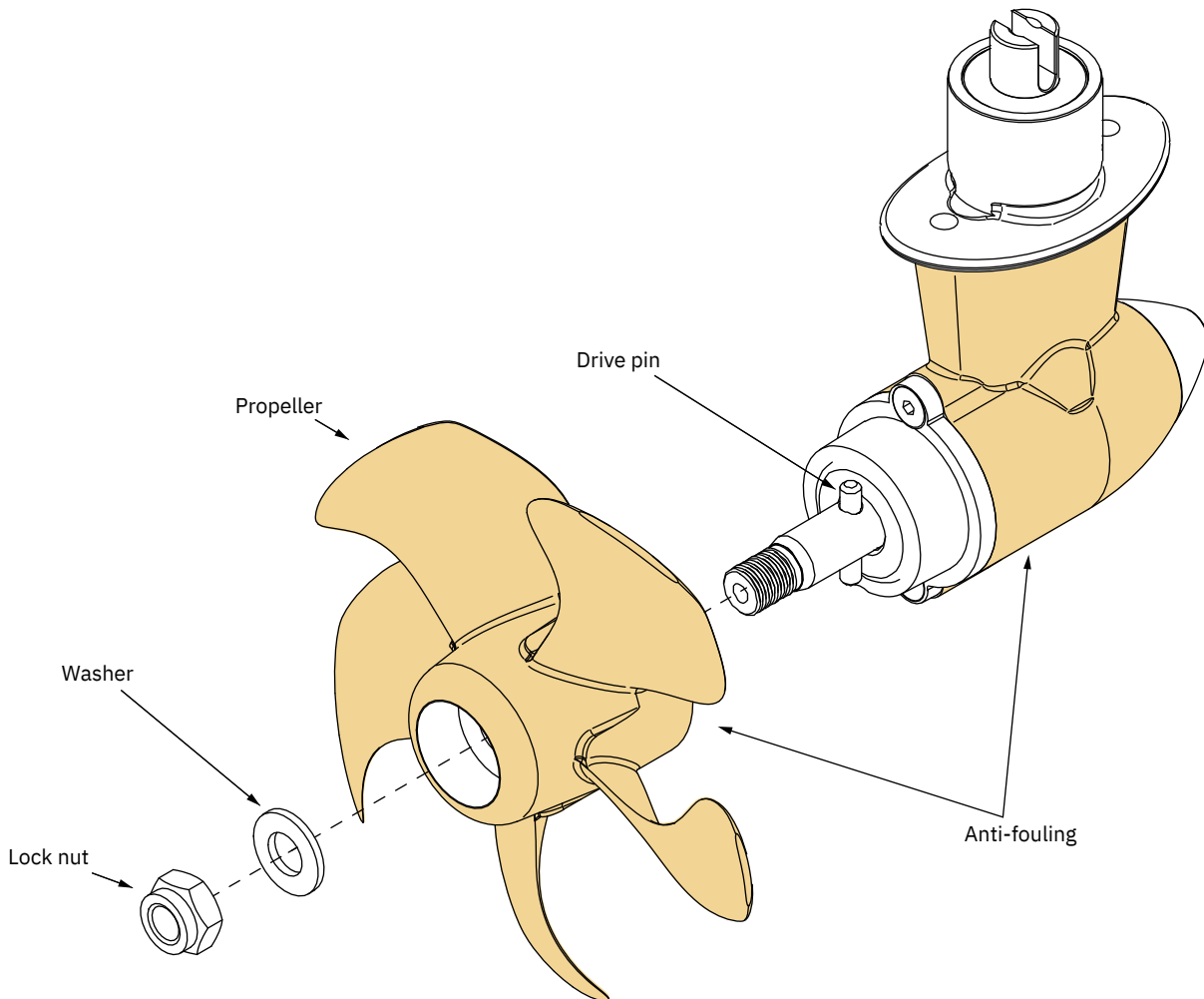

MG_0054

! Please refer to the graphic for special considerations relating to your model !

1. Insert the drive pin to the motor drive shaft. Insert the coupling to align with the drive pin in the motor shaft.
2. Install the motor onto the motor bracket ensuring the couplings are engaged together correctly (top and bottom). **(NB: The motor can be placed in all directions on the motor bracket. However, ensure the cable terminals are accessible for electrical installation later.)**
3. If you are installing the motor at an angle of more than 30 degrees off vertical, the motor will require separate/ additional support. **(NB: Do not position supports on the motors top cap.)**
4. Fasten the bolts holding the motor to the motor bracket with the above torque.
5. Check the drive shafts are engaged by rotating the propeller. **(NB: Rotating the propellers can be hard due to the gear reduction and the motor, however the propeller must be able to rotate via hand power.)**

IMPORTANT

The thruster motor assembly must be protected using suitable covering to avoid dust/debris ingress from fabrication/maintenance/shipbuilding operations. On completion of operations, the cover must be removed before operating the thruster.

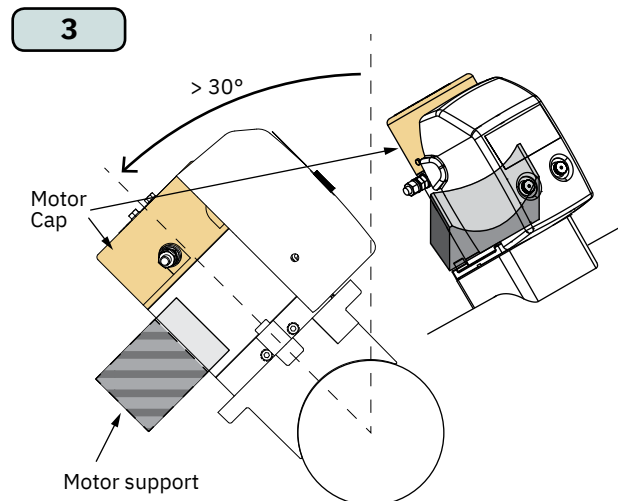
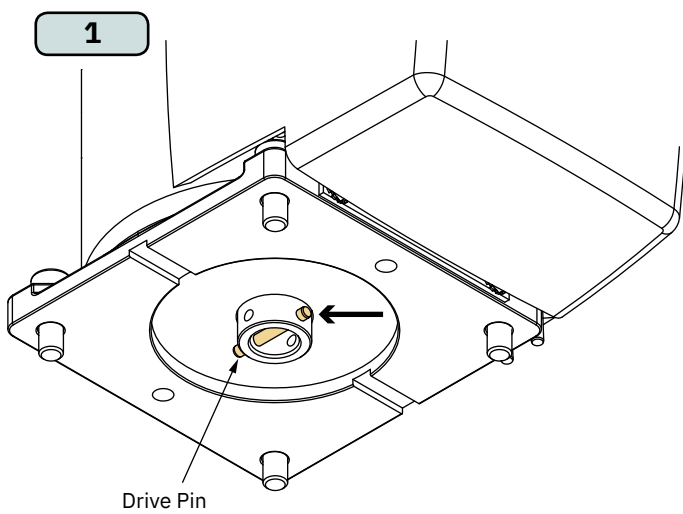

IMPORTANT
Do not position support on the motor cap.

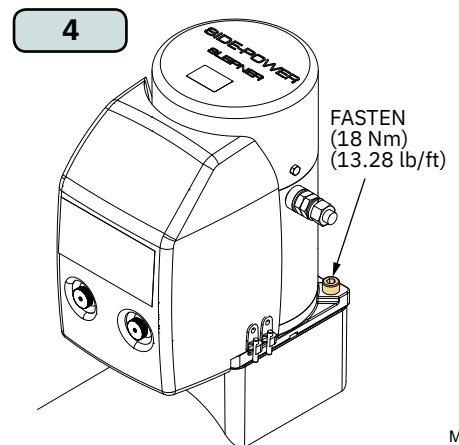
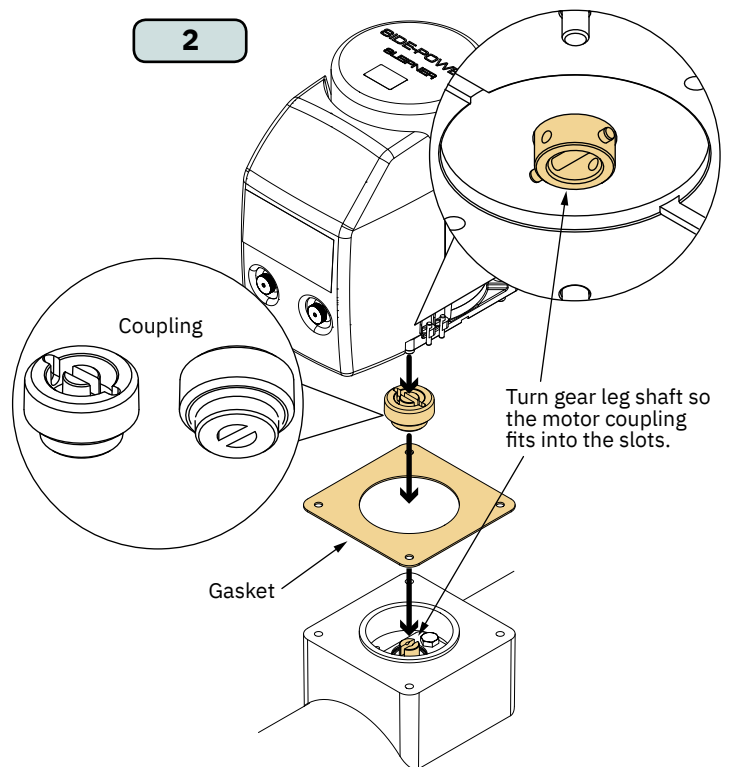

! Please refer to the graphic for special considerations relating to your model !

1. Information of electrical table. *see next page*
 - All power cable lengths represent the total length of the combined (+) and (-) cables.
 - Battery capacity is stated as minimum cold crank capacity, (CCA).
 - Use slow blow rated fuses to hold stated Amp-Draw for min. 5 minutes.
 - Consider the AMP hours (Ah) for your specific duty cycle.
2. Use appropriate sized cables and batteries with high cranking capacity to feed the thruster. The actual voltage at the motor while running the thruster decides the motors output RPM and thrust. Use larger cables and stronger batteries for better results.
 - See electrical specifications for advised minimum cables and batteries (CCA).
3. Install the main switch as close to the battery as possible and ensure the main positive lead can take loads without noticeable voltage drop.
 - Ensure the main switch (battery isolator) can be turned off independently and manually when not on board or in emergencies.
 - Ensure it is easily accessible and update instructions that this should be turned off like the boat's other main switches.

It is advised to install a fuse in the positive lead for protection against short-circuiting.
 - Ensure a slow type and appropriately sized to take the amperage draw for at least 5 minutes.

(NB: For Ignition Protected installations remember to use ignition protected fuses and switches if fitted in areas that require this feature. Ensure to follow your national regulations)

5. Cable lugs must have adequate electrical and mechanical isolation and fitted with cable lug covers.
6. Fasten cables to the required torque.

WARNING

Check the following with the main switch is set to off :
 After all electrical connections have been completed check with an ohm meter that there is no electrical connection between
 1. electro-motor flange and the positive terminal on the motor
 2. electro-motor flange and the battery negative terminal on the motor

If unsure contact skilled personnel.

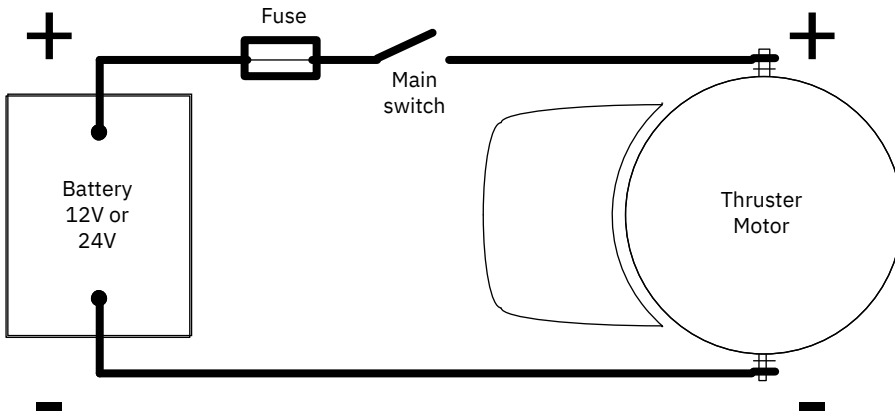

IMPORTANT
 Do NOT use washers between lugs, this causes overheating and fire. Spring washers must be placed in the outer position before tightening the nut.

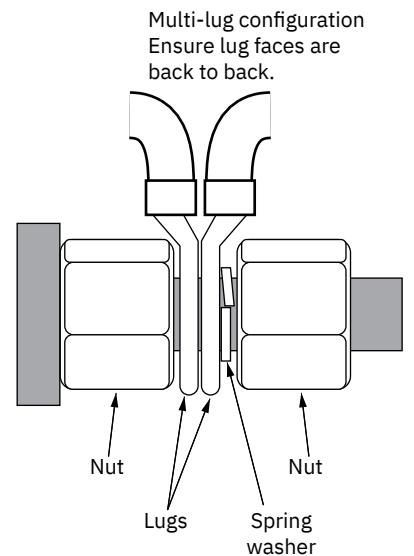
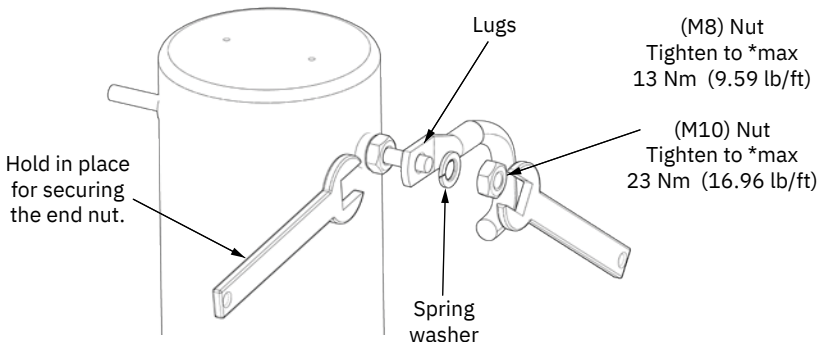

Cable Length Specifications

MC_0044

Model Size	System Voltage	Nominal current draw	Min. battery CCA	Rec. fuse		<7m total + & -		7-14m total + & -		15-21m total + & -		22-28m total + & -		28-35m total + & -		36-45m total + & -		
						Min.	Rec.	Min.	Rec.	Min.	Rec.	Min.	Rec.	Min.	Rec.	Min.	Rec.	Min.
20/110S	12 V	150 A	DIN: 200 SAE: 380 EN: 330	ANL 150	mm2	25	35	35	50	50	70	70	95	95	95	95	120	2 x 70
					AWG	3	2	2	1/0	1/0	2/0	2/0	3/0	3/0	3/0	3/0	2 x 4/0	2 x 2/0
25/110S	12 V	200 A	DIN: 200 SAE: 380 EN: 330	ANL 150	mm2	25	35	50	50	70	70	95	95	120	120	2 x 70	2 x 70	2 x 70
					AWG	3	2	1/0	1/0	2/0	2/0	3/0	3/0	4/0	4/0	2 x 2/0	2 x 2/0	2 x 2/0
30/125S 30/140	12 V	245 A	DIN: 200 SAE: 380 EN: 330	ANL 150	mm2	35	50	50	70	70	95	95	120	120	2 x 70	2 x 70	2 x 95	
					AWG	2	1/0	1/0	2/0	2/0	3/0	3/0	4/0	4/0	2 x 2/0	2 x 2/0	2 x 3/0	
40/125S 40/140	12 V	315 A	DIN: 300 SAE: 570 EN: 520	ANL 250	mm2	35	50	70	95	95	120	120	2 x 70	2 x 95	2 x 95	2 x 120	2 x 120	2 x 120
					AWG	2	1/0	2/0	3/0	3/0	4/0	4/0	2 x 2/0	2 x 3/0	2 x 3/0	2 x 4/0	2 x 4/0	2 x 4/0
50/140S	12 V	370 A	DIN: 350 SAE: 665 EN: 600	ANL 325	mm2	50	50	70	95	120	2 x 70	2 x 70	2 x 95	2 x 95	2 x 120	2 x 120	2 x 120	2 x 120
					AWG	1/0	1/0	2/0	3/0	4/0	2 x 2/0	2 x 2/0	2 x 3/0	2 x 3/0	2 x 4/0	2 x 4/0	2 x 4/0	2 x 4/0
	24 V	170 A	DIN: 175 SAE: 332 EN: 280	ANL 150	mm2	25	25	25	35	35	50	35	50	50	70	70	70	70
					AWG	3	3	3	2	2	1/0	2	1/0	1/0	2/0	2/0	2/0	2/0
60/185S 60/140	12 V	370 A	DIN: 350 SAE: 665 EN: 600	ANL 325	mm2	50	50	70	95	120	2 x 70	2 x 70	2 x 95	2 x 95	2 x 120	2 x 120	2 x 120	2 x 120
					AWG	1/0	1/0	2/0	3/0	4/0	2 x 2/0	2 x 2/0	2 x 3/0	2 x 3/0	2 x 4/0	2 x 4/0	2 x 4/0	2 x 4/0
	24 V	170 A	DIN: 175 SAE: 332 EN: 280	ANL 150	mm2	25	25	25	35	35	50	35	50	50	70	70	70	70
					AWG	3	3	3	2	2	1/0	2	1/0	1/0	2/0	2/0	2/0	2/0
80/185T	12 V	530 A	DIN: 550 SAE: 1045 EN: 940	ANL 400	mm2	70	70	120	2 x 70	2 x 95	2 x 95	2 x 120	2 x 120	2 x 120	NA	NA	NA	NA
					AWG	2/0	2/0	4/0	2 x 2/0	2 x 3/0	2 x 3/0	2 x 4/0	2 x 4/0	2 x 4/0	2 x 4/0	2 x 4/0	2 x 4/0	
	24 V	280 A	DIN: 300 SAE: 570 EN: 520	ANL 250	mm2	35	35	35	50	50	70	70	95	95	120	120	2 x 95	2 x 95
					AWG	2	2	2	1/0	1/0	2/0	2/0	3/0	3/0	4/0	4/0	2 x 3/0	2 x 3/0
100/185T	12 V	740 A	DIN: 750 SAE: 1425 EN: 1320	ANL 500	mm2	95	95	2 x 70	2 x 95	2 x 120	2 x 120	NA	NA	NA	NA	NA	NA	NA
					AWG	3/0	3/0	2 x 2/0	2 x 3/0	2 x 4/0	2 x 4/0	2 x 4/0	2 x 4/0	2 x 4/0	2 x 4/0	2 x 4/0	2 x 4/0	2 x 4/0
	24 V	340 A	DIN: 400 SAE: 760 EN: 680	ANL 325	mm2	50	50	50	70	70	95	95	120	120	2 x 95	2 x 95	2 x 120	2 x 120
					AWG	1/0	1/0	1/0	2/0	2/0	3/0	3/0	4/0	4/0	2 x 3/0	2 x 3/0	2 x 4/0	2 x 4/0
120/215T	24V	420 A	DIN: 450 SAE: 855 EN: 760	ANL 325	mm2	70	70	70	70	70	95	95	120	120	2 x 70	2 x 70	2 x 95	2 x 95
					AWG	2/0	2/0	2/0	2/0	2/0	3/0	3/0	4/0	4/0	2 x 2/0	2 x 2/0	2 x 3/0	2 x 3/0
130/250T	12V	800 A	DIN: 750 SAE: 760 EN: 680	ANL 500	mm2	95	95	2 x 95	2 x 95	2 x 120	2 x 120	NA	NA	NA	NA	NA	NA	NA
					AWG	3/0	3/0	2 x 2/0	2 x 3/0	2 x 4/0	2 x 4/0	2 x 4/0	2 x 4/0	2 x 4/0	2 x 4/0	2 x 4/0	2 x 4/0	2 x 4/0
	24V	350 A	DIN: 400 SAE: 760 EN: 680	ANL 325	mm2	50	50	50	70	70	95	95	120	120	2 x 70	2 x 95	2 x 95	2 x 95
					AWG	2	1/0	1/0	2/0	2/0	3/0	3/0	4/0	4/0	2 x 2/0	2 x 3/0	2 x 3/0	2 x 3/0
150/215T	24V	610 A	DIN: 560 SAE: 1064 EN: 940	ANL 500	mm2	70	70	95	95	120	120	2 x 70	2 x 95	2 x 95	2 x 120	2 x 120	2 x 120	2 x 120
					2	2/0	2/0	3/0	3/0	4/0	4/0	2 x 2/0	2 x 3/0	2 x 3/0	2 x 4/0	2 x 4/0	2 x 4/0	2 x 4/0
170/250	24V	550 A	DIN: 560 SAE: 1064 EN: 940	ANL 400	mm2	70	70	70	95	95	120	120	2 x 95	2 x 95	2 x 95	2 x 120	2 x 120	2 x 120
					AWG	2/0	2/0	2/0	3/0	3/0	4/0	4/0	2 x 3/0	2 x 3/0	2 x 3/0	2 x 4/0	2 x 4/0	2 x 4/0
210/250	24V	500 A	DIN: 560 SAE: 1330 EN: 940	ANL 400	mm2	70	70	70	95	95	120	120	2 x 70	2 x 70	2 x 95	2 x 95	2 x 95	2 x 120
					AWG	2/0	2/0	2/0	3/0	3/0	4/0	4/0	2 x 2/0	2 x 2/0	2 x 3/0	2 x 3/0	2 x 3/0	2 x 4/0
250/300	24V	610-670 A	DIN: 700 SAE: 1330 EN: 1170	ANL 500	mm2	70	70	95	120	120	2 x 95	2 x 95	2 x 95	2 x 95	2 x 120	2 x 120	2 x 120	2 x 120
					AWG	2/0	2/0	3/0	4/0	4/0	2 x 3/0	2 x 3/0	2 x 3/0	2 x 3/0	2 x 4/0	2 x 4/0	2 x 4/0	2 x 4/0
300/300	24*2	400-450A (48V)	DIN: 400 SAE: 760 EN: 680	ANL 325	mm2	50	70	50	70	70	95	95	120	120	120	140	140	NA
	48V				AWG	1/0	2/0	1/0	2/0	2/0	3/0	3/0	4/0	4/0	4/0	4/0	4/0	4/0

Technical Wiring Diagram

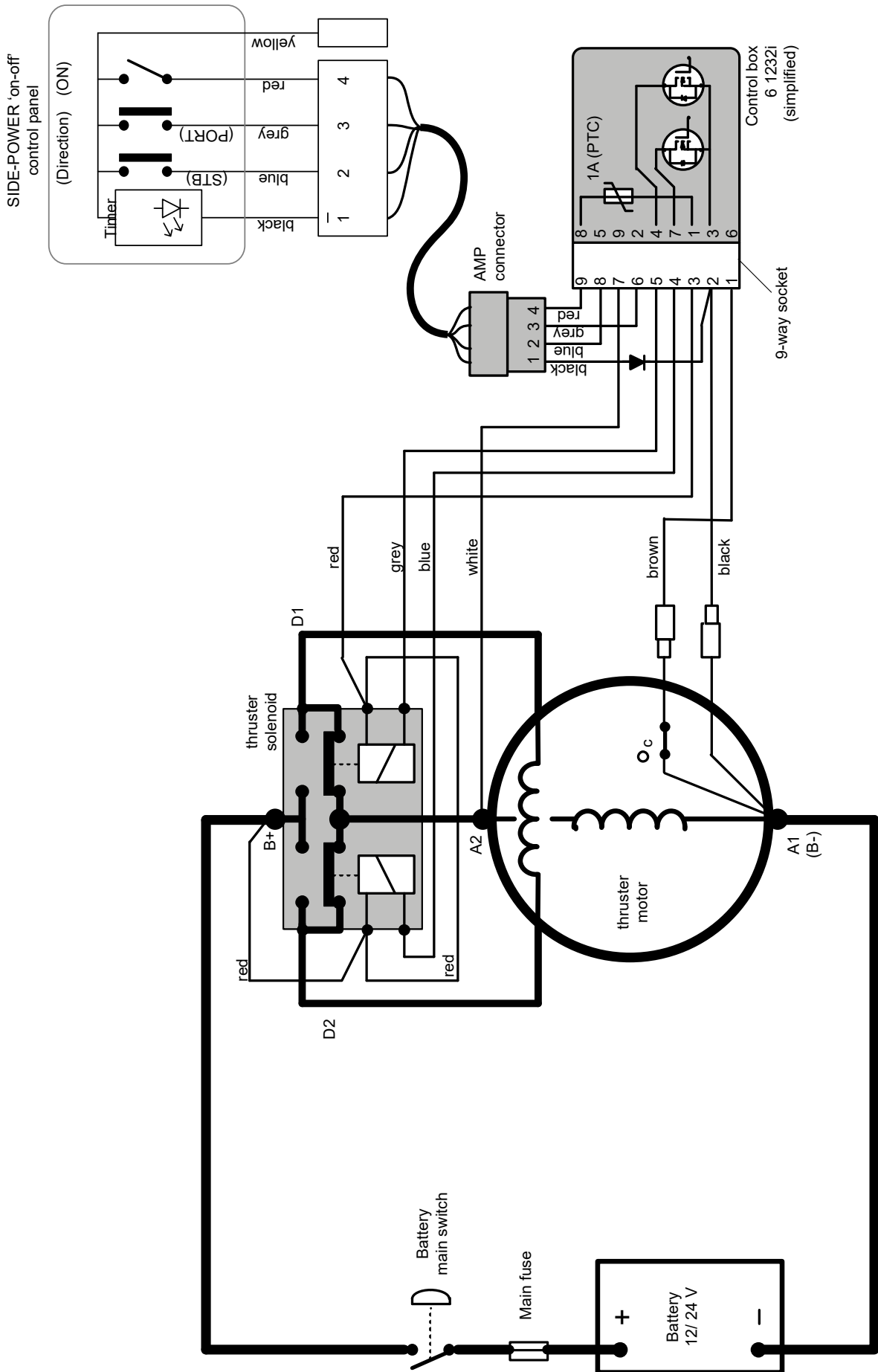

! Please refer to the graphic for special considerations relating to your model !

- All Sleipner control panels can be used in any combination.
- All control panels can be installed using:
 - Y-connectors - for standard on/off
 - T-connectors - for S-Link proportional power system.

(NB: If two or more control panels are operated at the same time in opposite directions, the electronic control box will stop the thruster until it receives a single signal or thrust in one direction.)

- Sleipner on/off equipment it is entirely “plug & play” and require no additional configuration setup.

See the Control panel manual for more information.

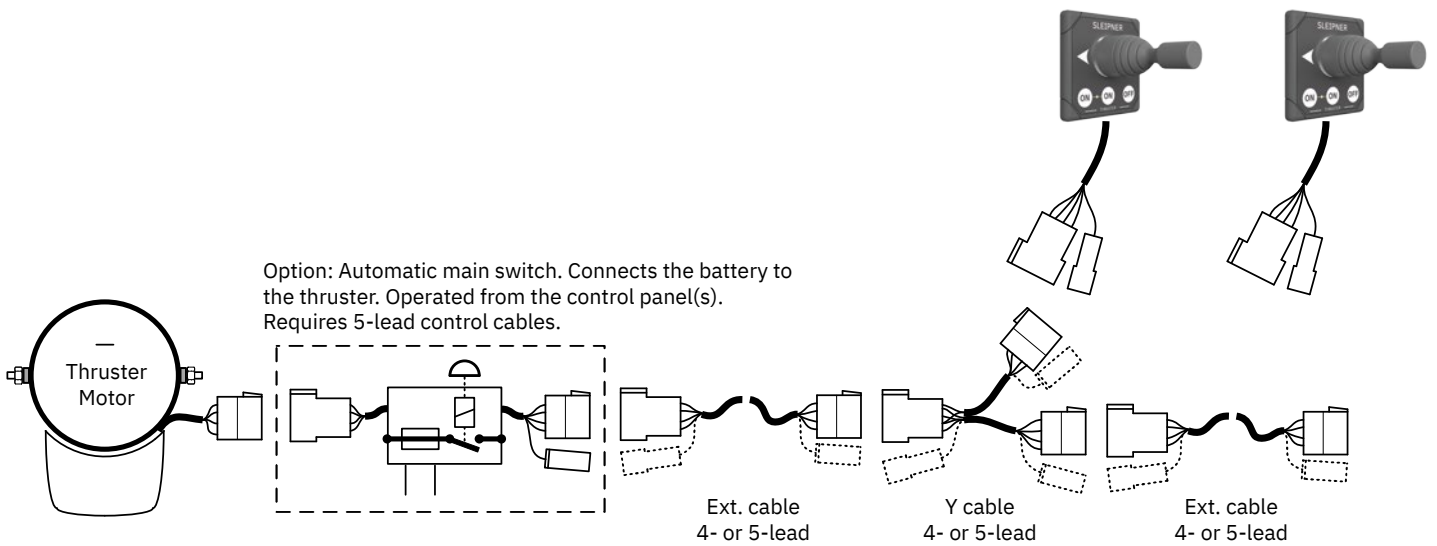

Visual Wiring Diagram

With Automatic Main Switch:

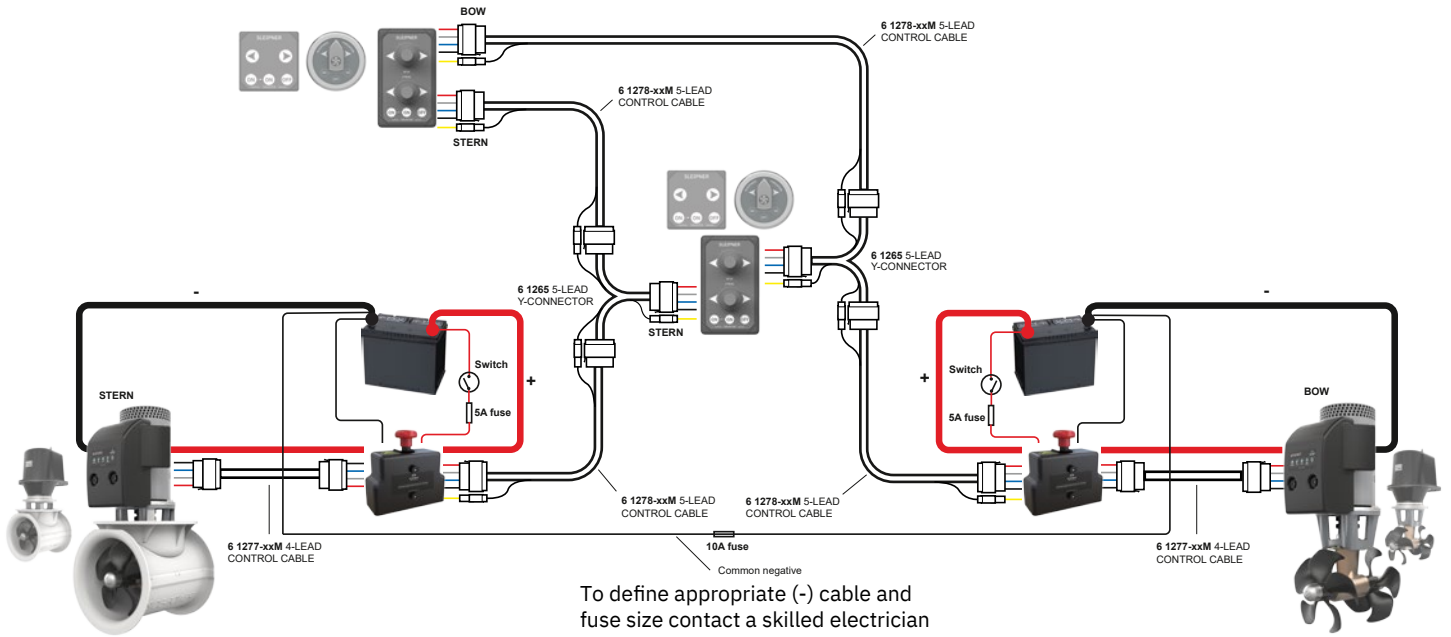

With Manual Main Switch:

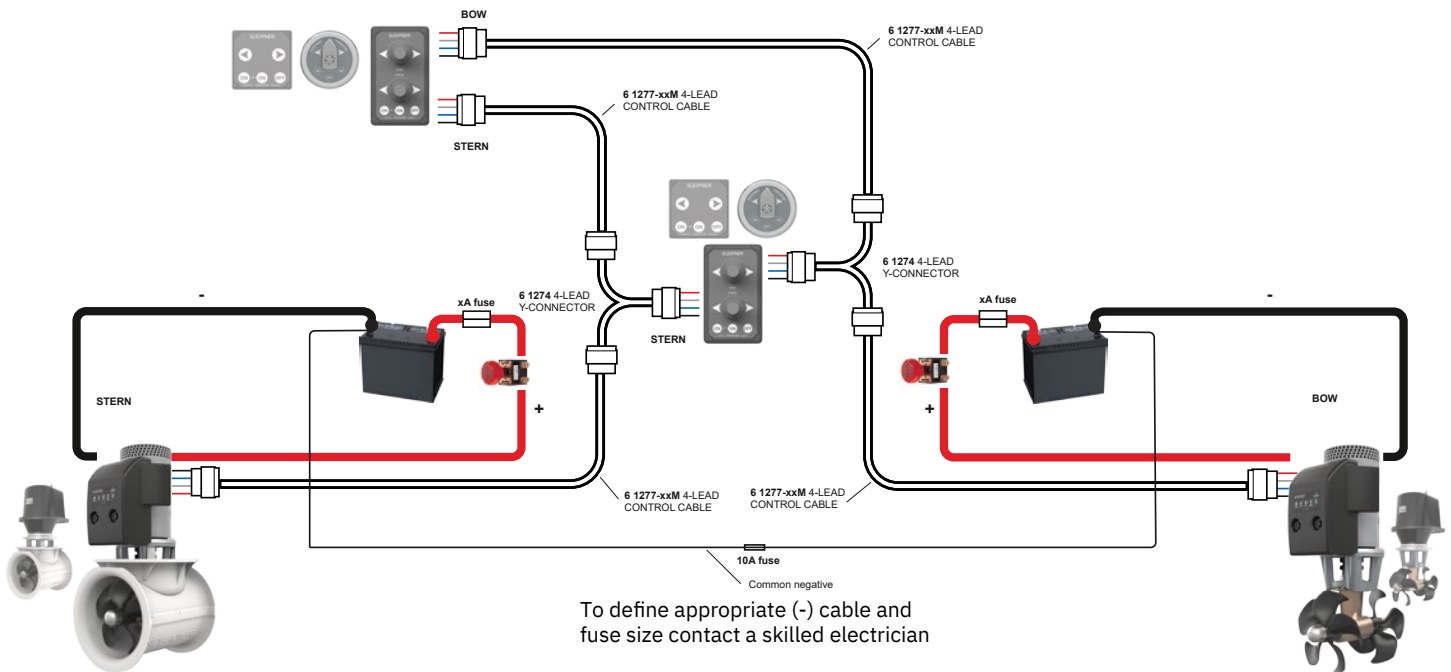

IMPORTANT

Check the following with the main switch in the off position

After all electrical connections have been completed check with an ohm meter that there is no electrical connection between electro motor body and positive terminal on the motor and between the electro motor body and the negative (A1) terminal on the motor. If you feel unsure about how to perform this check, contact skilled personnel for guidance

Common negative MUST be wired when using control panel 8940 and 8909C if separate battery banks are installed. (Bow and Stern thrusters combined)

For **Control Panel** installation please refer to the supplied manual in your Sleipner product delivery



- The bolts holding the gear house and motor bracket together are tightened correctly.
- The bolts holding the motor to its bracket are tightened correctly.
- All electrical connections are clean, dry and tight, and the correct cable, fuse and main switch size.
- Check that there is no electrical connection between the electro motor body and positive terminal on the motor, and between the electro motor body and the negative (A1) terminal on the motor with an ohm meter.
- Anti-fouling has been applied to the gear house and propeller but NOT anodes, sealing/ rubber fittings or propeller shafts.
- Propeller is fastened correctly to the shaft.
- Propeller turns freely in tunnel.
- The anode and/ or holding screw is tightened well with thread glue.
- Check the boat for potential water leakage around installation areas.
- Correct drive direction as per control panel.
- User Manual is supplied to the owner.

The thruster has been installed as per the instructions in this manual and all points in checklist above have been controlled.

Signed:

Date:

Thruster type:

Serial number:.....

Date of delivery:.....

Correct drive direction as per control panel:

The compartment for the thruster has been isolated from general bilge water and has no obvious or suspected risks for flooding:

.....
.....
.....

Other comments by installer:

.....
.....

Find your local professional dealer from our certified worldwide network for expert service and support. visit our website www.sleipnergrouper.com/support

Product Spare Parts and Additional Resources

For additional supporting documentation, we advise you to visit our website www.sleipnergrouper.com and find your Sleipner product.

Warranty statement

1. Sleipner Motor AS (The “Warrantor”) warrants that the equipment (parts, materials, and embedded software of products) manufactured by the Warrantor is free from defects in workmanship and materials for purpose for which the equipment is intended and under normal use and maintenance service (the “Warranty”).
2. This Warranty is in effect for two years (Leisure Use) or one year (Commercial and other Non-leisure Use) from the date of delivery/purchase by the end user, with the following exceptions;
 - (a) For demonstration vessels, or vessels kept on the water, the dealer is considered as the end user from 6 months after their launch of the vessel;
 - (b) The warranty period starts no later than 18 months after the first launch of the vessel.
 Please note that the boat manufacturer and dealer must pay particular attention to correct maintenance and service both by the products manuals as well as general good practice for the location the boat is kept in the period the boat is in their care. In cases where the 6 and 18 months grace periods for boat builders and dealers are passed, it is possible to obtain a full warranty upon inspection and approval of the warrantor or such representative.
3. Certain parts, classified as wearable or service parts, are not covered by the warranty. A failure to follow the required maintenance and service work as described in the product manual render all warranty on parts or components directly or indirectly affected by this void. Please also note that for some parts, time is also a factor separately from actual operational hours.
4. This Warranty is transferable and covers the equipment for the specified warranty period.
5. The warranty does not apply to defects or damages caused by faulty installation or hook-up, abuse or misuse of the equipment including exposure to excessive heat, salt or fresh water spray, or water immersion except for equipment specifically designed as waterproof.
6. In case the equipment seems to be defective, the warranty holder (the “Claimant”) must do the following to make a claim:
 - (a) Contact the dealer or service centre where the equipment was purchased and make the claim. Alternatively, the Claimant can make the claim to a dealer or service centre found at www.sleipnergrouper.com. The Claimant must present a detailed written statement of the nature and circumstances of the defect, to the best of the Claimant’s knowledge, including product identification and serial nbr., the date and place of purchase and the name and address of the installer. Proof of purchase date should be included with the claim, to verify that the warranty period has not expired;
 - (b) Make the equipment available for troubleshooting and repair, with direct and workable access, including dismantling of furnishings or similar, if any, either at the premises of the Warrantor or an authorised service representative approved by the Warrantor. Equipment can only be returned to the Warrantor or an authorised service representative for repair following a pre-approval by the Warrantor’s Help Desk and if so, with the Return Authorisation Number visible postage/shipping prepaid and at the expense of the Claimant.
7. Examination and handling of the warranty claim:
 - (a) If upon the Warrantor’s or authorised service Representative’s examination, the defect is determined to result from defective material or workmanship in the warranty period, the equipment will be repaired or replaced at the Warrantor’s option without charge, and returned to the Purchaser at the Warrantor’s expense. If, on the other hand, the claim is determined to result from circumstances such as described in section 4 above or a result of wear and tear exceeding that for which the equipment is intended (e.g. commercial use of equipment intended for leisure use), the costs for the troubleshooting and repair shall be borne by the Claimant;
 - (b) No refund of the purchase price will be granted to the Claimant, unless the Warrantor is unable to remedy the defect after having a reasonable number of opportunities to do so. In the event that attempts to remedy the defect have failed, the Claimant may claim a refund of the purchase price, provided that the Claimant submits a statement in writing from a professional boating equipment supplier that the installation instructions of the Installation and Operation Manual have been complied with and that the defect remains.
8. Warranty service shall be performed only by the Warrantor, or an authorised service representative, and any attempt to remedy the defect by anyone else shall render this warranty void.
9. No other warranty is given beyond those described above, implied or otherwise, including any implied warranty of merchantability, fitness for a particular purpose other than the purpose for which the equipment is intended, and any other obligations on the part of the Warrantor or its employees and representatives.
10. There shall be no responsibility or liability whatsoever on the part of the Warrantor or its employees and representatives based on this Warranty for injury to any person or persons, or damage to property, loss of income or profit, or any other incidental, consequential or resulting damage or cost claimed to have been incurred through the use or sale of the equipment, including any possible failure or malfunction of the equipment or damages arising from collision with other vessels or objects.
11. This warranty gives you specific legal rights, and you may also have other rights which vary from country to country.

Patents

At Sleipner we continually reinvest to develop and offer the latest technology in marine advancements. To see the many unique designs we have patented visit our website www.sleipnergrouper.com/patents

Dotted lines for writing.

Area with horizontal dotted lines for writing notes.

© **Sleipner Group**, All rights reserved
The information given in the document
was right at the time it was published.
However, Sleipner Group cannot
accept liability for any inaccuracies or
omissions it may contain. Continuous
product improvement may change the
product specifications without notice.
Therefore, Sleipner Group cannot accept
liability for any possible differences
between product and document.

**Register your product and learn more
at www.sleipnergroun.com**



SLEIPNER AS

P.O. Box 519

N-1612 Fredrikstad

Norway

www.sleipnergroun.com

Made in Norway



Keep this
manual onboard!



User Manual

For Thruster Models
DC SE & SE-IP Electric



SLEIPNER AS

P.O. Box 519

N-1612 Fredrikstad

Norway

www.sleipnergroup.com

DOCUMENT ID: 5915

REVISION: II

DATE: 2022

LANGUAGE: EN

U
M

To download your language go to www.sleipnergroup.com

Contents

User Manual

Responsibility of the user operating thrusters	3
General user considerations and precautions for electric thrusters	3
General user considerations and precautions for DC electric motors	3
General user considerations and precautions for IP systems	3
User operation	4
Compatible control device products	4
Control panel	5
Maintenance	6 - 8
Basic troubleshooting	9
Seasonal checklist	10
Service and Support	11
Product Spare Parts and Additional Resources	11
Warranty Statement	11

Products

SE300/300TC - SE300 Tunnel thruster, 48V
SE250/300TC - SE250 Tunnel thruster, 24V
SE210/250TC - SE210 Tunnel thruster, 24V
SE170/250TC-AM - Sidepower SE170-TC-Amel 24V
SE170/250TC-AMS - Sidepower S-link SE170-TC-Amel
SE170/250TC-AMR - Sidepower SE170-TC-Amel Retrac
SE170/250TC - SE170 Tunnel thruster, 24V
SE150/215T-24V - SE150 Tunnel thruster, 24V
SE150/215T-24 - SE150 Tunnel thruster, 24V
SE130/250T-12V - SE130 Tunnel thruster, 12V
SE130/250T-24V - SE130 Tunnel thruster, 24V
SE120/215T-24V - SE120 Tunnel thruster, 24V
SE120/215T-24 - SE120 Tunnel thruster, 24V
SE100/185T-24V - SE100 Tunnel thruster, 24V
SE100/185T-12V - SE100 Tunnel thruster, 12V
SE80/185T-12V - SE80 Tunnel thruster, 12V
SE80/185T-24V - SE80 Tunnel thruster, 24V
SE60/185S-24V - SE60 Tunnel thruster, 24V
SE60/185S-12V - SE60 Tunnel thruster, 12V
SE60/185S2-12V - SE60 Tunnel thruster, 12V
SE60/185-12V OST - SE60 Tunnel thruster, 12V
SE60/185S2-24V - SE60 Tunnel thruster, 24V
SE50/140S-12V - SE50 Tunnel thruster, 12V
SE50/140S-24V - SE50 Tunnel thruster, 24V
SE40/140S-ALU - SE40 Tunnel thruster, 12V
SE40/140 SPESIAL - SE40 Tunnel thruster, 12V
SE40/125S2 - SE40 Tunnel thruster, 12V
SE40/140S - SE40 Tunnel thruster, 12V
SE40/125S - SE40 Tunnel thruster, 12V
SE30/140S - SE30 Tunnel thruster, 12V
SE30/125S - SE30 Tunnel thruster, 12V
SE30/125S2 - SE30 Tunnel thruster, 12V
SE25/110S - SE25 Tunnel thruster, 12V
SE20/110S - SE20 Tunnel thruster, 12V
SE170/250TC-IP - SE170 Tunnel thruster, 24V-IP
SE130/250T-12IP - SE130 Tunnel thruster, 12V-IP
SE130/250T-24V - SE130 Tunnel thruster, 24V
SE130/250T-24IP - SE130 Tunnel thruster, 24V-IP
SE120/215T-24IP - SE120 Tunnel thruster, 24V-IP
SE100/185T-12IP - SE100 Tunnel thruster, 12V-IP
SE100/185T-24IP - SE100 Tunnel thruster, 24V-IP
SE80/185T-12IP - SE80 Tunnel thruster, 12V-IP
SE80/185T-24IP - SE80 Tunnel thruster, 24V-IP
SE60/185S-24V - SE60 Tunnel thruster, 24V
SE60/185S2-12IP - SE60 Tunnel thruster, 12V-IP
SE60/185S-24IP - SE60 Tunnel thruster, 24V-IP
SE60/185S-12IP - SE60 Tunnel thruster, 12V-IP
SE50/140S-24IP - SE50 Tunnel thruster, 24V-IP
SE50/140S-12IP - SE50 Tunnel thruster, 12V-IP
SE40/125S2-12IP - SE40 Tunnel thruster, 12V-IP
SE40/125S-12IP - SE40 Tunnel thruster, 12V-IP
SE30/125S2-12IP - SE30 Tunnel thruster, 12V-IP
SE30/125S-12IP - SE30 Tunnel thruster, 12V-IP
SE60/185S2-24IP - SE60 Tunnel thruster, 24V-IP
SE60/185S2-24V - SE60 Tunnel thruster, 24V



Sleipner Motor AS
P.O. Box 519, Arne Svendsensgt. 6-8
N-1612 Fredrikstad, Norway

MC_0020

Failure to follow the considerations and precautions can cause serious injury, damage and will render all warranties given by Sleipner Motor as VOID.

MC_0411

General Operation Considerations and Precautions Guidelines

MC_0444

For the operation of thrusters

MC_0418

Never use thrusters when close to objects, persons or animals in the water. The thruster will draw objects into the tunnel and the rotating propellers. This will cause serious injuries and damage the thruster.

Always turn the main power switch off before touching any part of the thruster. An incidental start while touching moving parts can cause serious injuries.

It is the owner, captains or other responsible parties full responsibility to assess the risk of any unexpected incidents on the vessel. If the thruster stops giving thrust for some reason while manoeuvring you must have considered a plan on how to avoid damage to persons or other objects.

- Always turn the control device off when the thruster is not in use or when leaving the boat.
- When leaving the boat always turn off the main power switch for the thruster.
- Never use thrusters out of water.
- If the thruster stops giving thrust while running, there is possibly a problem in the drive system. You must immediately stop running the thruster and turn it off. Running the thruster for more than a few seconds without resistance from the propeller can cause serious damage to the thruster.
- If two panels are operated with conflicting directions at the same time the thruster will not run. If both are operated in the same direction, the thruster will run in this direction.
- If you notice any faults with the thruster switch it off to avoid further damage.
- The primary purpose of the thruster is to manoeuvre or dock the vessel. Forward or reverse speed must not exceed 4 knots when operated.

For the operation of electric thrusters

MC_0004

Never store items (e.g. equipment, sails, ropes etc.) in the same compartment as the thruster. When the thruster runs for an extended period, it can reach 150°C and will cause damage to nearby items or cause a fire.

Any loose items near the thruster motor can cause problems with electrical wiring coming loose and short-circuiting.

- Ensure you know the location of the main battery switch that disconnects the thruster from all power sources (batteries) so the thruster can be turned off in case of serious malfunction.
- We advise keeping the main engine(s) running while using the thruster. This will keep the batteries in a good charge condition. It will also give better performance to the thruster.
- If the performance of the thruster is reduced check the battery system or check the tunnel for marine growth.
- The electric motor, its components, contacts/ plugs or other joints in the control cables must be mounted so they will remain dry at all times.

For the operation of DC electric motors

MC_0419

- The DC electric motor will generate some carbon dust during operation. Ensure any storage compartments are separated from the thruster area to prevent nearby items from becoming dusty.
- The maximum continuous run time of the electrical thruster is approximately 3 minutes. The electrical motor includes a built-in thermal cut off switch that will shut down the motor when it detects overheating. Consider this when planning your manoeuvring.

NEVER Disassemble any part of the Ignition Protected assembly. Tampering with the Ignition Protected assembly will cause it to lose this safety feature. If there is a problem with your Ignition Protected motor, please contact your dealer.

MC_0007

! Please refer to the graphic for special considerations relating to your model !

The following is an operation guide to ALL Sleipner control products. Ensure to familiarise yourself with the functionality and operation of your specific control device.

Take time to practice operation in open water to become familiar with the thruster and to avoid damages to your boat or people.

General operation

1. Turn on the main power switch for the bow thruster. *(NB: Always turn off the main power switch when not on-board.)*
2. Turn on the control panel by pushing the/ both "ON" button(s) on the original Sleipner panel simultaneously.
*Turn off the control panel by pushing the "OFF" button
3. To Turn the bow/ stern in the desired direction:

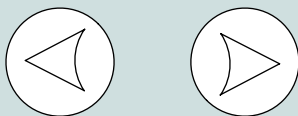

Button control panels

For button control, push the button in the corresponding direction you wish the bow/ stern to move.

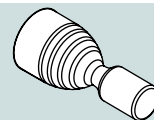

Joystick control panels

For joystick control, move the joystick in the direction you wish the bow/ stern to move.

(NB: If equipped for proportional control move the joystick equivalent to the amount of thrust you intend to receive.)

* For other controls like foot switches or toggle-switches please refer to that products user manual for detailed operational use.

Hold functionality

If equipped with 'hold' functionality push the button in the corresponding direction you wish the thrusters to engage a holding pattern:

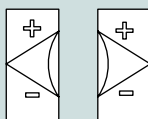

Hold Button

+ or -

Will increase or decrease the holding force output of the thrusters

Operating a combined bow and stern thruster

The combination of a bow and stern thruster offers total manoeuvrability to move the bow and the stern separately from each other or in unison. This enables the boat to move sideways in both directions or turn the boat around a 360° axis while staying stationary.

Remote controls

Ensure the remote control is held in the same direction as the boat during operation.

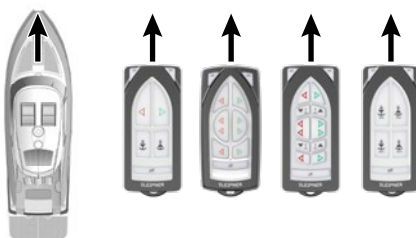

Drift

Depending on the sideways speed of the bow/ stern, you must disengage the control device shortly before the vessel is in the desired position.

(NB: Be aware the boat will continue to move after disengaging the thruster control.)

At any significant cruising speed (+1-2 kn) the side thruster will have little effect to steer the vessel.

Compatible Control Device Products

! Please refer to the graphic for special considerations relating to your model !

ON/ OFF CONTROL PANEL



REMOTE CONTROL



For additional information refer to your control device manual



Control Panel

Activating the bow thruster

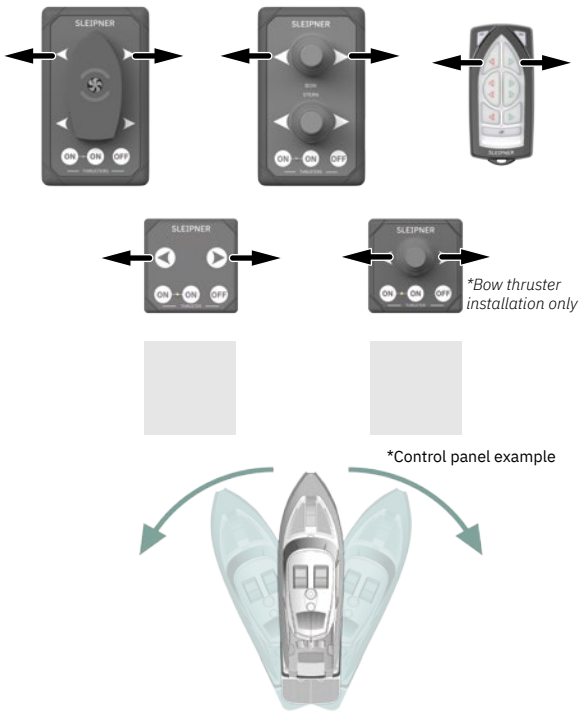

Activating the stern thruster

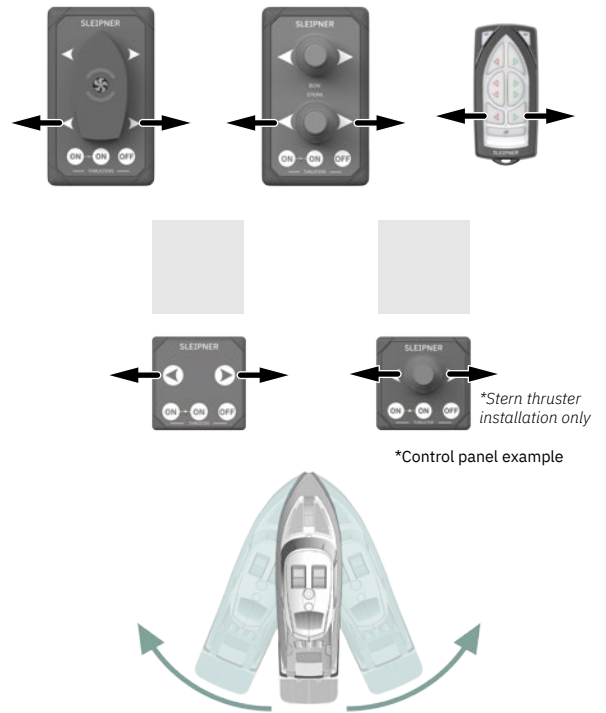

Activating both bow and stern thruster to push the boat sideways

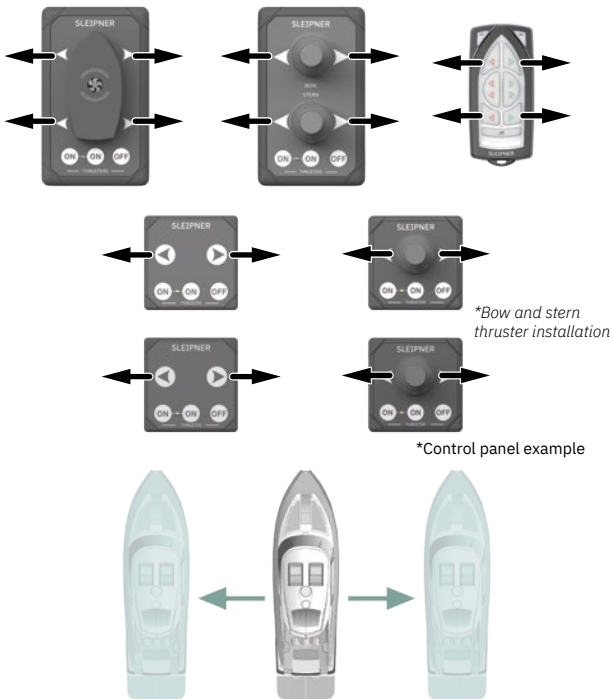

Activating both bow and stern thruster to rotate the boat on axis

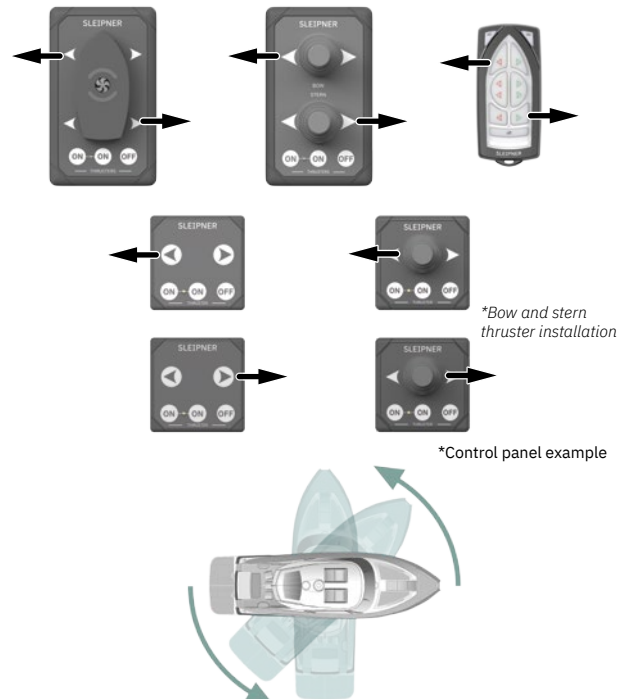

As a part of the seasonal service of your Thruster before every season, always check that:

In Water

- The area around the thruster inside the boat is clean and dry. Ensure there are no signs of water leaks.
- All electrical connections are clean and fastened firmly.
- Ensure that your batteries are in good condition.

Out of Water

- Check the propeller(s) or tunnel for any damage for example impact damage.
- The propeller(s) is fastened securely to the gear leg.
- Check all components of thruster are fastened securely.
- Clean the tunnel and gear leg from marine growth.
- Paint the propeller and gear leg with anti-fouling before every season to keep it clean from sea growth. **(NB: Never paint the anode, sealing or propeller shaft. Ensure paint does not enter the space between the propeller and the gear leg.)**
- Change the anode before every season, or when half the anode has eroded. Always use a sealant or thread glue on the holding screw to ensure that it does not fall off.
- Check the gear leg is not leaking oil

NEVER Disassemble any part of the Ignition Protected assembly. Tampering with the Ignition Protected assembly will cause it to lose this safety feature. If there is a problem with your Ignition Protected motor, please contact your dealer.

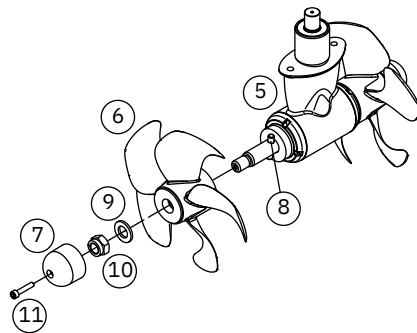
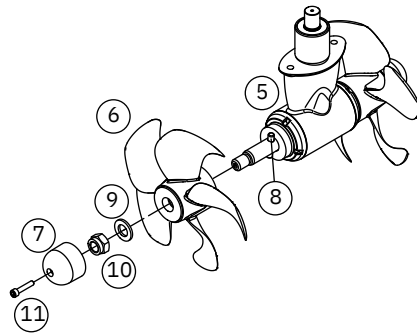
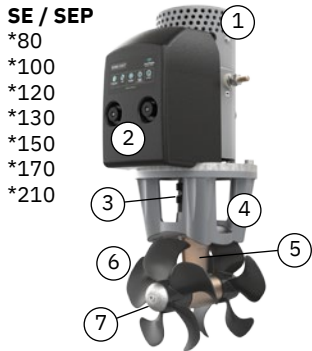
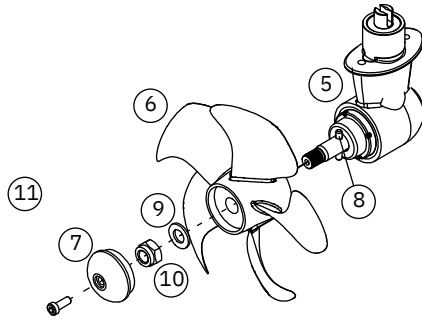
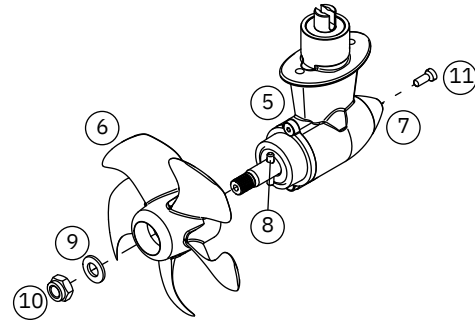
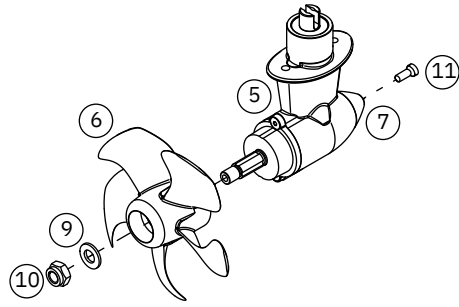

KEY:

- 1. Electro motor
- 2. Directional Solenoids/ power & control cables
- 3. Coupling (inside motor bracket)
- 4. Motor Bracket
- 5. Gear Leg
- 6. Propeller
- 7. Anode
- 8. Propeller Drive pin
- 9. Washer
- 10. Lock Nut
- 11. Fastening Screw for anode

SE / SEP (IP)

*30

*40

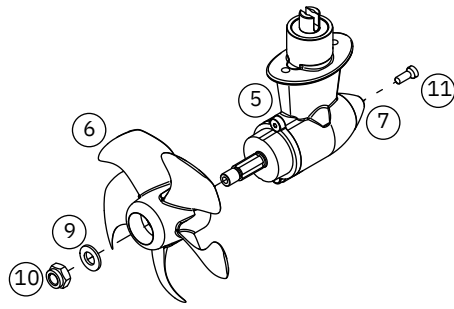

SE / SEP (IP)

*50

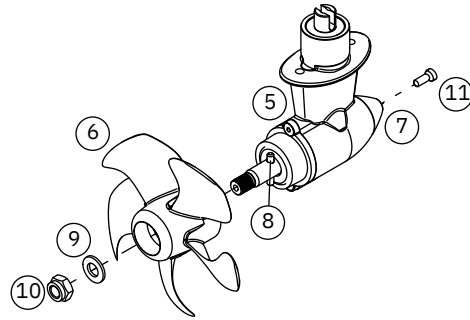

SE / SEP (IP)

*60

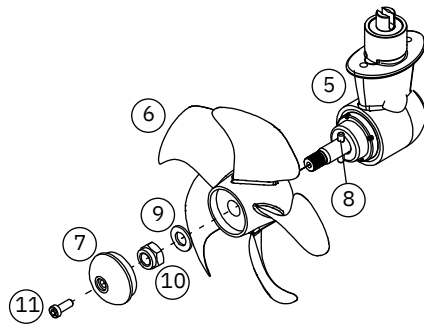

SE / SEP (IP)

*80

*100

*120

*130

*170

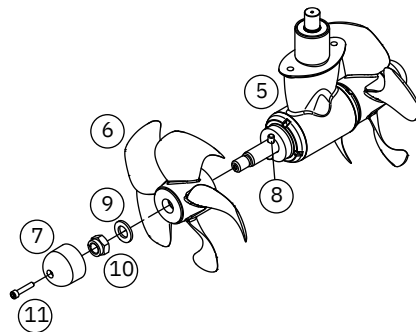

KEY:

- 1. Electro motor
- 2. Directional Solenoids/ power & control cables
- 3. Coupling (inside motor bracket)
- 4. Motor Bracket
- 5. Gear Leg
- 6. Propeller
- 7. Anode
- 8. Propeller Drive pin
- 9. Washer
- 10. Lock Nut
- 11. Fastening Screw for anode

Before seeking assistance from the website help desk from your Sleipner dealer/ distributor, please perform these tests.

(NB: If you are unable to understand or perform these checks, you must consult a Sleipner distributor.)

CHECK	SOLUTION
The motor runs, but there is no thrust	
Check propellers are fitted, fastened correctly and there is no damage to the prop shaft.	Re-fasten or replace if necessary
* Check the flexible coupling between the motor and drive shaft is fitted correctly and not damaged.	Replace if necessary
* Check the gear leg is not damaged.	Replace if necessary
The thrusters performance is reduced	
Check the propeller, gear house and tunnel are free from growth/ barnacles or debris and damage.	Remove growth and clean. (NB: If there is obstruction in the tunnel it will disturb/ block the water flow and significantly reduce performance.)
Check the battery is in a good working condition.	(NB: Keep the main engine(s) running in use to have a continuous charge to the batteries) <ul style="list-style-type: none"> • Check batteries are not worn out or in a bad charged condition • Check electrical connections/ wiring for damage or wear (corrosion) • Check cables are the correct size per the product manual • Tighten/ re-adjust connections
The thruster does not start/ works in only one direction or does not turn off	
Check the main switch is active/ on.	Open the main switch if it is closed.
Check all battery fuses are in good condition.	<ul style="list-style-type: none"> • Check batteries • Check electrical connections/ wiring for damage or wear (corrosion) • Tighten/ re-adjust and clean connections <div style="text-align: right; margin-top: -10px;">} Replace if necessary</div>
The thruster is not shutting off after the Joy Stick/ panel is disengaged.	Hit the main switch to disengage the thruster. Contact and consult a Sleipner distributor as the control system has been damaged.
The thruster works in only one direction	
Damaged relay.	Hit the main switch to disengage the thruster. Contact and consult a Sleipner distributor as the control system has been damaged.
The thruster runs in a pulsing action	
This is a build-in error response. -Solenoids failure	Hit the main switch to disengage the thruster. Contact and consult a Sleipner distributor.
The solenoid might be in a lock-in/ auto stop position.	Hit the main switch to disengage the thruster. Contact and consult a Sleipner distributor.

* Not applicable to SX thrusters.

CHECK TO PERFORM	DATE											
The propeller is fastened securely to the gear leg.												
The thruster components are fastened securely.												
The area around the thruster is clean and dry. If there are signs of water, try to find the source and eliminate it.												
Apply the propeller and gear leg with anti-fouling.												
Batteries are in good condition.												
All electrical connections are clean and fastened firmly.												
Replace the anode.												

Find your local professional dealer from our certified worldwide network for expert service and support.

visit our website www.sleipnergrou.com/support

Product Spare Parts and Additional Resources

For additional supporting documentation, we advise you to visit our website www.sleipnergrou.com and find your Sleipner product.

Warranty statement

1. Sleipner Motor AS (The "Warrantor") warrants that the equipment (parts, materials and embedded software of products) manufactured by the Warrantor is free from defects in workmanship and materials for the purpose for which the equipment is intended and under normal use and service (the "Warranty").
2. This Warranty is in effect for two years (Leisure Use) or one year (Commercial and other Non-leisure Use) from the date of purchase by the end user (for demonstration vessels, the dealer is deemed as end user).
3. This Warranty is transferable and covers the equipment for the specified warranty period.
4. The warranty does not apply to defects or damages caused by faulty installation or hook-up, abuse or misuse of the equipment including exposure to excessive heat, salt or fresh water spray, or water immersion except for equipment specifically designed as waterproof.
5. In case the equipment seems to be defective, the warranty holder (the "Claimant") must do the following to make a claim:
 - (a) Contact the dealer or service centre where the equipment was purchased and make the claim. Alternatively, the Claimant can make the claim to a dealer or service centre found at www.sleipnergrou.com. The Claimant must present a detailed written statement of the nature and circumstances of the defect, to the best of the Claimant's knowledge, including product identification and serial nbr., the date and place of purchase and the name and address of the installer. Proof of purchase date should be included with the claim, to verify that the warranty period has not expired;
 - (b) Make the equipment available for troubleshooting and repair, with direct and workable access, including dismantling of furnishings or similar, if any, either at the premises of the Warrantor or an authorised service representative approved by the Warrantor. Equipment can only be returned to the Warrantor or an authorised service representative for repair following a pre-approval by the Warrantor's Help Desk and if so, with the Return Authorisation Number visible postage/shipping prepaid and at the expense of the Claimant.
6. Examination and handling of the warranty claim:
 - (a) If upon the Warrantor's or authorised service Representative's examination, the defect is determined to result from defective material or workmanship in the warranty period, the equipment will be repaired or replaced at the Warrantor's option without charge, and returned to the Purchaser at the Warrantor's expense. If, on the other hand, the claim is determined to result from circumstances such as described in section 4 above or a result of wear and tear exceeding that for which the equipment is intended (e.g. commercial use of equipment intended for leisure use), the costs for the troubleshooting and repair shall be borne by the Claimant;
 - (b) No refund of the purchase price will be granted to the Claimant, unless the Warrantor is unable to remedy the defect after having a reasonable number of opportunities to do so. In the event that attempts to remedy the defect have failed, the Claimant may claim a refund of the purchase price, provided that the Claimant submits a statement in writing from a professional boating equipment supplier that the installation instructions of the Installation and Operation Manual have been complied with and that the defect remains.
7. Warranty service shall be performed only by the Warrantor, or an authorised service representative, and any attempt to remedy the defect by anyone else shall render this warranty void.
8. No other warranty is given beyond those described above, implied or otherwise, including any implied warranty of merchantability, fitness for a particular purpose other than the purpose for which the equipment is intended, and any other obligations on the part of the Warrantor or its employees and representatives.
9. There shall be no responsibility or liability whatsoever on the part of the Warrantor or its employees and representatives based on this Warranty for injury to any person or persons, or damage to property, loss of income or profit, or any other incidental, consequential or resulting damage or cost claimed to have been incurred through the use or sale of the equipment, including any possible failure or malfunction of the equipment or damages arising from collision with other vessels or objects.
10. This warranty gives you specific legal rights, and you may also have other rights which vary from country to country.

Patents

At Sleipner we continually reinvest to develop and offer the latest technology in marine advancements. To see the many unique designs we have patented visit our website www.sleipnergrou.com/patents

© **Sleipner Group**, All rights reserved
The information given in the document
was right at the time it was published.
However, Sleipner Group cannot
accept liability for any inaccuracies or
omissions it may contain. Continuous
product improvement may change the
product specifications without notice.
Therefore, Sleipner Group cannot accept
liability for any possible differences
between product and document.

**Register your product and learn more
at www.sleipnergroun.com**



SLEIPNER AS

P.O. Box 519

N-1612 Fredrikstad

Norway

www.sleipnergroun.com

Made in Norway

