

Installation Guide

For Pro DC External Electric Thruster Models
SXP35, SXP50



SLEIPNER AS

P.O. Box 519

N-1612 Fredrikstad

Norway

www.sleipnergroun.com

DOCUMENT ID: 5926

REVISION: 20

DATE: 2021

LANGUAGE: EN

MI

Contents

Installation Manual

Responsibility of the Installer.....	3 - 4
Thruster Measurements	5
Thruster Specifications	6
Technical Specifications	6
Control Box Technical Specifications.....	7
Positioning the Stern Thruster	8
Stern Thruster Cowls/ Grids	9
Grids or Cowls Assembly.....	10
Tunnel Installation	11
SX Spacer	12
Motor Installation	13
Propeller Installation.....	14
Control Box Installation.....	15
Thruster Electrical Installation	16 - 17
Electrical Specifications	18
Control Panel Cable Installation	19
S-Link System Description	20
Control Panel Installation	21
Pre-delivery Checklist	22
Service and Support.....	23
Product Spare Parts and Additional Resources.....	23
Warranty Statement.....	23

Products

SXP50/140-12V-150MM - SXP50/140 w/Controller and PPC
SXP50/140-12V-50MM - SXP50/140 w/Controller and PPC
SXP35/140-12V-50MM - SXP35/140 w/Controller and PPC
SXP35/140-12V-150MM - SXP35/140 w/Controller and PPC



Sleipner Motor AS
P.O. Box 519, Arne Svendsensgt. 6-8
N-1612 Fredrikstad, Norway

MC_0020

Failure to follow the considerations and precautions can cause serious injury, damage and will render all warranties given by Sleipner Motor as VOID.

MC_0411

Responsibility of the Installer

MC_0038

The installer must read this document to ensure necessary familiarity with the product before installation.

Instructions in this document cannot be guaranteed to comply with all international and national regulations. It is the responsibility of the installer to follow all applicable international and national regulations when installing Sleipner products.

The recommendations given in this document are guidelines ONLY, and Sleipner strongly recommends that advice is obtained from a person familiar with the particular vessel and applicable regulations.

This document contains general installation instructions intended to support experienced installers. If you are not skilled in this type of work, please contact professional installers for assistance.

If required by local regulation, electrical work must be done by a licensed professional.

Appropriate health and safety procedures must be followed during installation.

Faulty installation of Sleipner products will render all warranties given by Sleipner Motor AS.

General Installation Considerations and Precautions for Thrusters

MC_0425

- Do not install the thruster in a position where you need to cut a stiffener/ stringer/ support that may jeopardise the hull integrity without checking with the boat builder this can be done safely.
- We advise painting the gear house and propellers with anti-fouling. **(NB: Do not paint the anodes, sealing, rubber fittings or propeller shafts)**
- Do not finish the inside of the tunnel with a layer of gel-coat/ topcoat or similar. There is only room for a thin coat of primer and two layers of anti-fouling between the tunnel and the props.
- Never run the thruster out of water.
- The electro/ hydraulic motor must be handled with care. Do not place down the motor on the drive shaft.

General Installation Considerations and Precautions for Electric Thrusters

MC_0031

- The thruster must NOT be installed in compartments that require ignition proof electric equipment. If necessary, make a separate compartment. **(NB: Ignition Protected systems are tested to be installed in areas with possible explosive gases in accordance with ISO 8846)**
- When installing the thruster electro motor in small compartments, ensure the compartment is well ventilated to allow for cooling of the electro motor.
- If the height of the room you are installing the thruster is limited, the thruster can be installed horizontally or at any angle in-between.
 - If the electro motor is positioned more than 30 degrees off vertical, it must be supported separately.
 - Beware of keeping installation within advised measurements. No part of the propeller or gear house must be outside the tunnel.
- Do not install the thruster in a position where you need to cut a stiffener/ stringer/ support that may jeopardise the hull integrity without checking with the boat builder this can be done safely.
- The electro motor, components and cables must be mounted so they remain dry at all times.
- We advise painting the gear house and propellers with anti-fouling. **(NB: Do not paint the anodes, sealing, rubber fittings or propeller shafts)**
- Do not finish the inside of the tunnel with a layer of gel-coat/ topcoat or similar. There is only room for a thin coat of primer and two layers of anti-fouling between the tunnel and the props.
- Don't install the electro motor close to easily flammable objects or equipment as it will reach over 100°C before the temperature switch is activated.
- Do not store items close to the thruster motor. Any loose items near the thruster motor is a potential fire hazard and can cause undesired short-circuiting.
- Do not lift it by internal cable connections, main terminals.
- The thruster power supply circuit must include the recommended sized fuse and a battery isolation switch.

General Installation Considerations and Precautions for DC Electric Motors

MC_0426

- The electro motor will generate some carbon dust so any storage compartments must be separated from the thruster to prevent nearby items becoming dusty/ dirty. **(NB: IP version motors generate dust but are enclosed.)**

Failure to follow the considerations and precautions can cause serious injury, damage and will render all warranties given by Sleipner Motor as VOID.

MC_0411

General Installation Considerations and Precautions for SX Thrusters

MC_0427

- The external thruster assembly and controller unit are ignition protected and can be installed in areas with the chance of explosive gases in accordance to ISO 8846 and ABYC c1500. (Certification pending)
- Ensure that the external thruster assembly does not disturb the water flow under the hull. At higher speeds, if the thruster is installed too low it can cause damage to the thruster and/ or add additional drag and unwanted water splashing.
- The recommended minimum tunnel depth from the water surface is 140mm (5,51') to the centre of tunnel diameter. Place the Thruster as deep as possible for better performance and reduced noise.
- When installing the thruster ensure it does not foul existing equipment inside the boat like motor bedding etc.
- If able ensure that stern-drives/ trim-tabs do not interfere with the water flow from the thruster as this can reduce the thrust effectiveness considerably. We recommend the use of our Sleipner cowls to enhance the performance and allow installation in shallow draft boats. Sleipner cowls will also minimise the effect if stern-drives/ trim-tabs obstruct the thruster.
- Ensure there is enough space both inside and outside the transom of the boat and the thruster does not get in conflict with existing equipment inside the boat like steering links etc. **(NB: It is possible to mount the tunnel offset from the boat's centre line if necessary.)**
- Heat protection cut off is calculated from the thruster motor. To avoid cable overheating do not install place the volt cables from the thruster to the control box near any heat sources.

General User Considerations and Precautions for IP Systems

MC_0007

NEVER Disassemble any part of the Ignition Protected assembly. Tampering with the Ignition Protected assembly will cause it to lose this safety feature. If there is a problem with your Ignition Protected motor, please contact your dealer.

Considerations and Precautions for S-Link Systems

MC_0105

When installing an S-Link™ system DO NOT connect any other control equipment directly to the S-Link™ bus except original Sleipner S-Link™ products. In case of connecting third-party equipment, it must always be connected through a Sleipner-supplied interface product. Any attempt to directly control or connect into the S-Link™ control system without a designated and approved interface will render all warranties and responsibilities of all of the connected Sleipner products.

If you are interfacing the S-Link™ bus by agreement with Sleipner through a designated Sleipner supplied interface, you are still required to install at least one original Sleipner control panel to enable efficient troubleshooting if necessary.

Measurement code	Measurement description	*35 12v		*50 12v	
		mm	inch	mm	inch
H	Motor Height	374	14.72	374	14.72
W	Width	183	7.20	183	7.20
L	Length	171	6.7	171	6.7
+L	Standard tube length	108	4.3	108	4.3
++L	Extended tube length for thicker hulls	276	10.9	276	10.9
(a)	Height of support bolts from tube	35.8	1.4	35.8	1.4
(b)	Main tube diameter	50	2	50	2
(c)	Support bolts diameter	18	0.7	18	0.7
(d)	Distance of support bolts from tube	65	2.6	65	2.6
(e)	Distance of support bolts	130	5.1	130	5.1

*Valid for SX & SXP

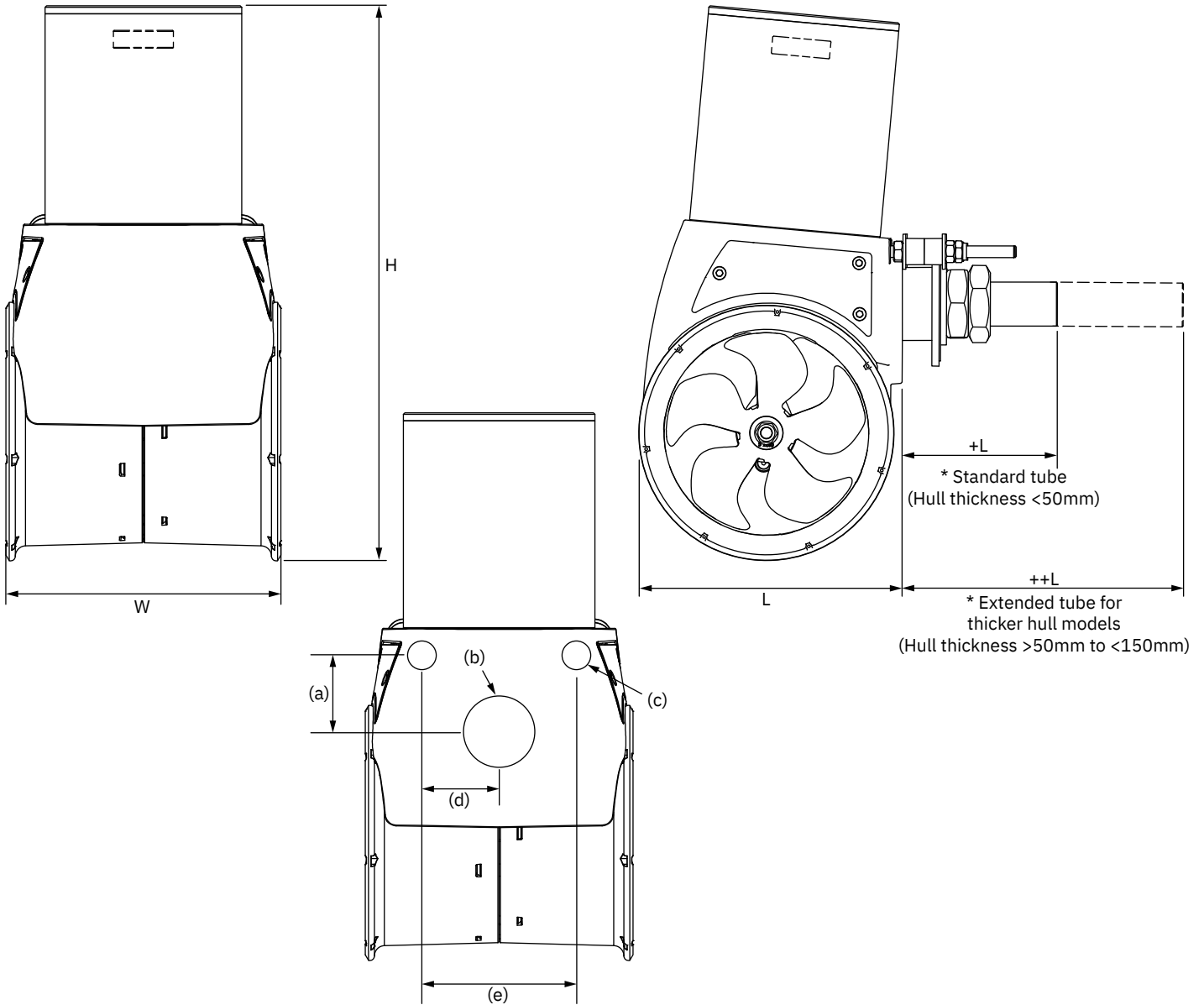

Description	* 35	* 50
Available DC System (v)	12v	12v
Thrust 12v or 24v (kg * lbs)	43 kg * 94 lbs	62 kg * 136 lbs
Thrust 10.5v or 21v (kg * lbs)	35 kg * 77 lbs	50 kg * 110 lbs
Typical Boat Size (m * ft)	6m - 10m * 19ft - 32ft	8m - 11m * 27ft - 37ft
Propulsion System	Single	Single
Power (kw * Hp)	1.8kw * 2hp	2.8kw * 3.75hp
Weight (kg * lbs)	15.3 kg * 33.73 lbs	15.3 kg * 33.73 lbs

Technical Specifications

- Motor:** Custom made reversible DC-motor.
- Gear house:** Seawater resistant aluminium. Ball-bearing and ceramic axial seals at propeller shaft and a combination of ball bearing/ slide bearing at drive shaft. (Pre-filled and sealed for life)
- Motor bracket:** Seawater resistant aluminium, galvanization insulated from the motor.
- Tunnel:** Hydrodynamic fibreglass reinforced snap on composite.
- Propeller:** 5-blade skewback "Q-prop" propeller, fibreglass reinforced composite.
- Batteries:** Minimum recommended battery capacity (cold crank capacity by DIN/SAE standard)
Contact a battery supplier for more information.
- Max. Use:** 2 - 3 min. duty cycle at 20°
- Safety features:**
- Electronic time-lapse device protects against sudden change of drive direction.
 - The electric thermal cut-off switch in electro motor protects against overheating (auto-reset when electro motor cools down).
 - Original SLeipner panels shut off automatically 6 minutes after last use.
 - Original SLeipner panels use child-safe double ON buttons.
 - An integrated microprocessor monitors solenoids, reduce wear and risk of solenoid lock-in.
 - Auto-stop of the thruster occurs when an undesirable solenoid lock-in occurs or when continuous operation cut-off timer exceeds 3 minutes.

	SX35	SX50
Operation volts:	12v.	12v
Max Current:	250A	380A
Duty Cycle:	S2.	S2
Max ambient temp:	50°C	50°C
Min ambient temp:	-25°C	-25°C
Power supply cable:	35 - 70mm ² / AWG 2 - 00	35 - 70mm ² / AWG 2 - 00
Mount direction :	Any	Any

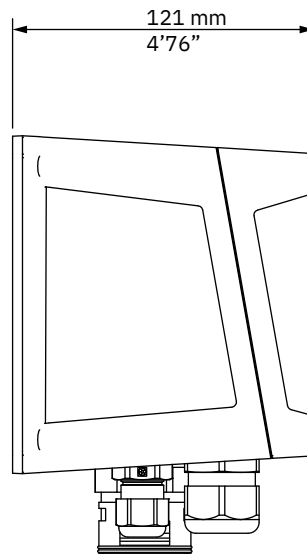
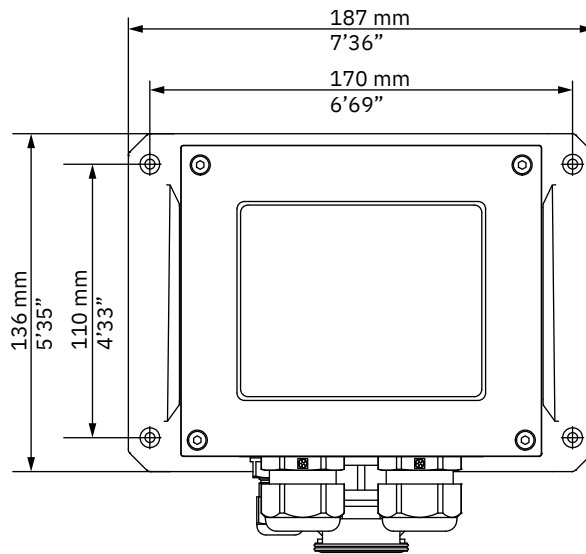

For best performance, the thruster must be installed as deep on the stern as possible and the thrusters water flow must not obstruct any objects.

The thruster should be installed as deep under the waterline as possible for two reasons:

1. So it does not suck air from the surface which will reduce performance and increase noise levels.
2. To receive maximum efficiency and thrust.

The thruster must be installed to ensure the propulsion water flow must not be obstructed by other objects. Objects that obstruct the water flow will greatly reduce the thrust output.

Position

The thruster can be installed in multiple locations on the boat transom. Installing the thruster slightly off centre will not affect the overall effectiveness of the thruster. Installing the thruster off centre may be required to avoid any obstructions externally or internally on the vessel.

Ensure that the external stern thruster assembly does not disturb the water flow under the hull. At higher speeds, if the thruster is installed to low can cause damage to the thruster, additional drag and unwanted water splashing.

Alignment

The thruster can be installed at a slight angle if required for the water flow to avoid obstructions. These obstructions can include propellers systems, trim tabs or the hull. The average force the thruster propels water is 5-7 meters per sec, therefore angled installations must be as deep as possible under the water to minimise spray breaking beyond the water surface. **(NB: install the thruster at an angle only if no other suitable location can be found.)**

Max hull thickness 50mm include spacer

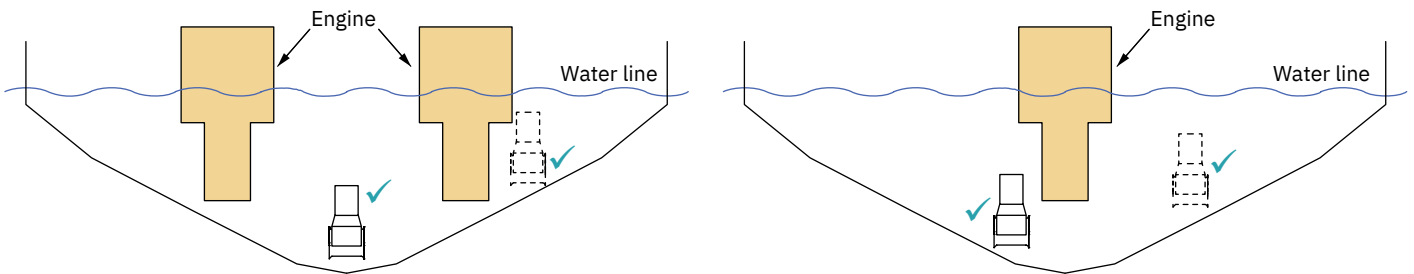

The thruster can be installed in multiple locations based on object obstructions on the stern.

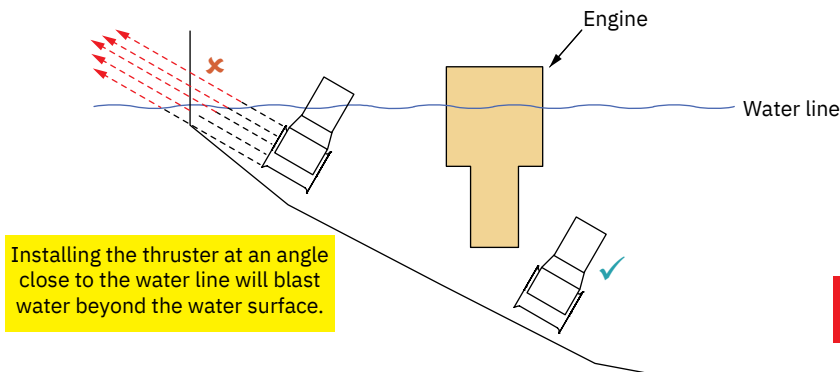
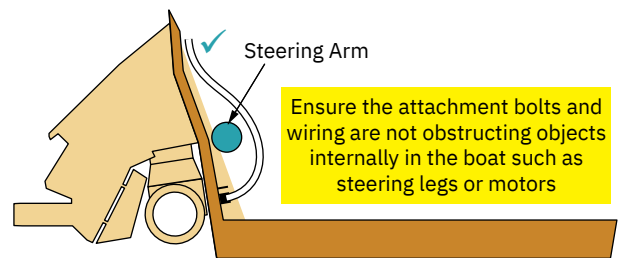
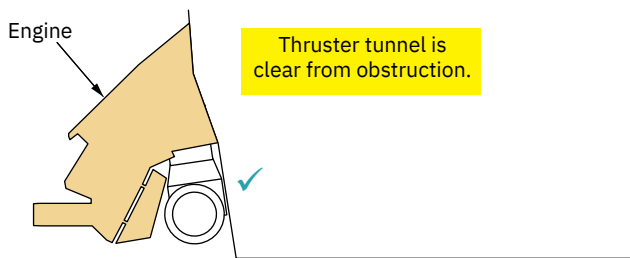
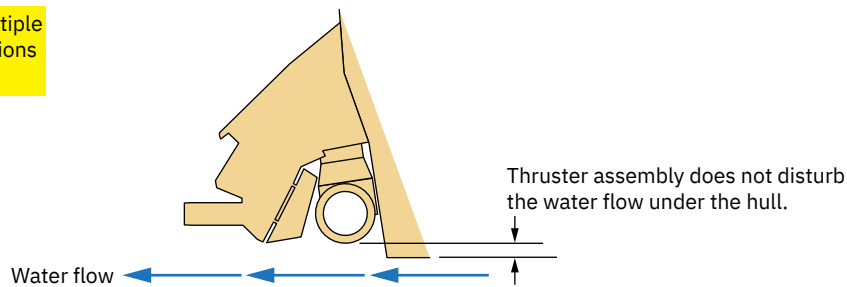

This guide applies to SX 35, 50, 80 & 100

Installing a stern thruster cowl for stern thrusters that will allow installations in boats with shallow drafts or due to other obstructions on the stern. These can include obstacles such as trim tabs, jets or surface drive propeller systems where shallow installation of a stern thruster is the only option.

Cowls:

Designed to aid in water redirection and reduce air entering the tunnel in shallow installations.

Grid's:

Designed to protect the thruster from objects while in use.

IMPORTANT

Install the cowls/ grids before mounting the tunnel to the SX thruster.

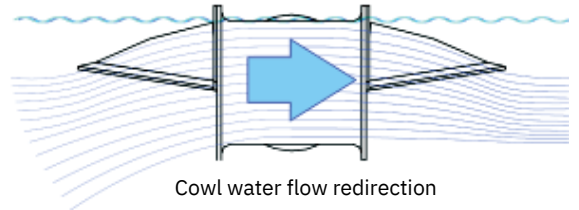
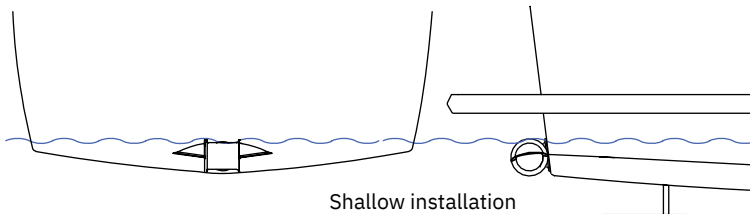

Composite material with smooth inner walls for optimal water flow and strength

Radius corners prevent turbulence

An angled edge further preventing air attraction into the tunnel

Easy installation for easy bolt-on fitting

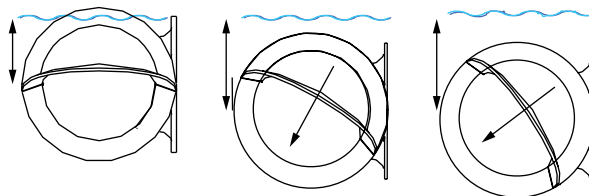
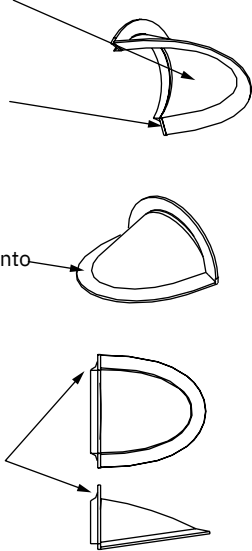

cowls to change the water flow direction to avoid obstructions on the stern

cowls help prevent air from the water surface entering the tunnel in shallow installations

IMPORTANT

Angled cowls out of horizontal, must be installed deeper to avoid air entry in the thruster tunnel

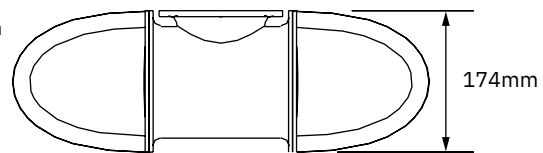
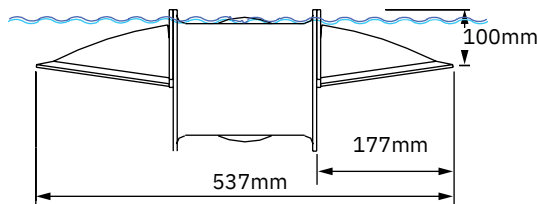

! Please refer to the graphic for special considerations relating to your model !

1. Ensure to remove the plastic cover guard on the tunnel.
2. Connect both ends of the tunnel to the thruster motor. All hooks must be completely interlocked making the inside of the tunnel smooth. **(NB: Ensure tunnel moulding around the gear leg and tunnel top align.)**

IMPORTANT

Ensure all snap-lock positions are correctly connected into place.

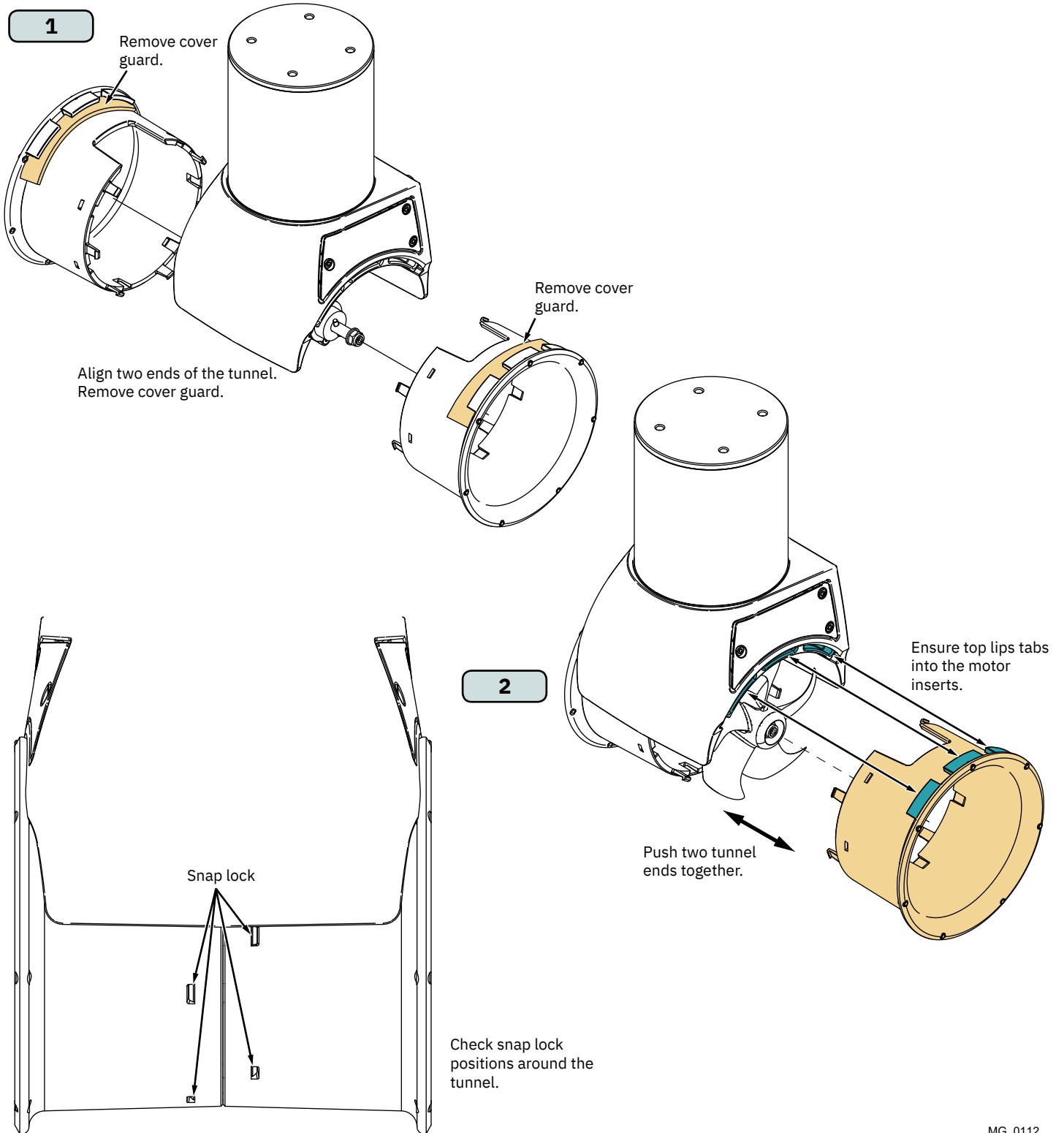

MG_0112

! Please refer to the graphic for special considerations relating to your model !

Follow the installation of the SX thruster in the **Motor Installation** to step 3. see next page

1. Define the location to install the thruster. **(NB: Ensure the thruster does not protrude past the transom profile on any side and there is no obstruction to the thrusters water flow. Also, check internally the thruster will not obstruct any objects.)**
 2. Mark the locations of the three drill holes using the defined measurements in this manual or from a template. **(NB: Maximum hull thickness is 50mm including optional spacer or 150mm for extended hull thickness models.)**
 3. Drill main hole, then two support bolt holes. Clean the area from dust for installation of the thruster. **(NB: Hull holes must be drilled first before attaching the spacer as the top support holes are larger than the spacers.)**
-
4. Drill out the two support bolt holes in the spacer.
 5. Apply MS Polymer sealant or equal to the back surface face of the spacer.
 6. Place the spacer to the hull.

Continue the installation of the SX thruster from step 4 in the **Motor Installation**.

IMPORTANT

If using the 50mm spacer ensure you have the extended tube SX model.

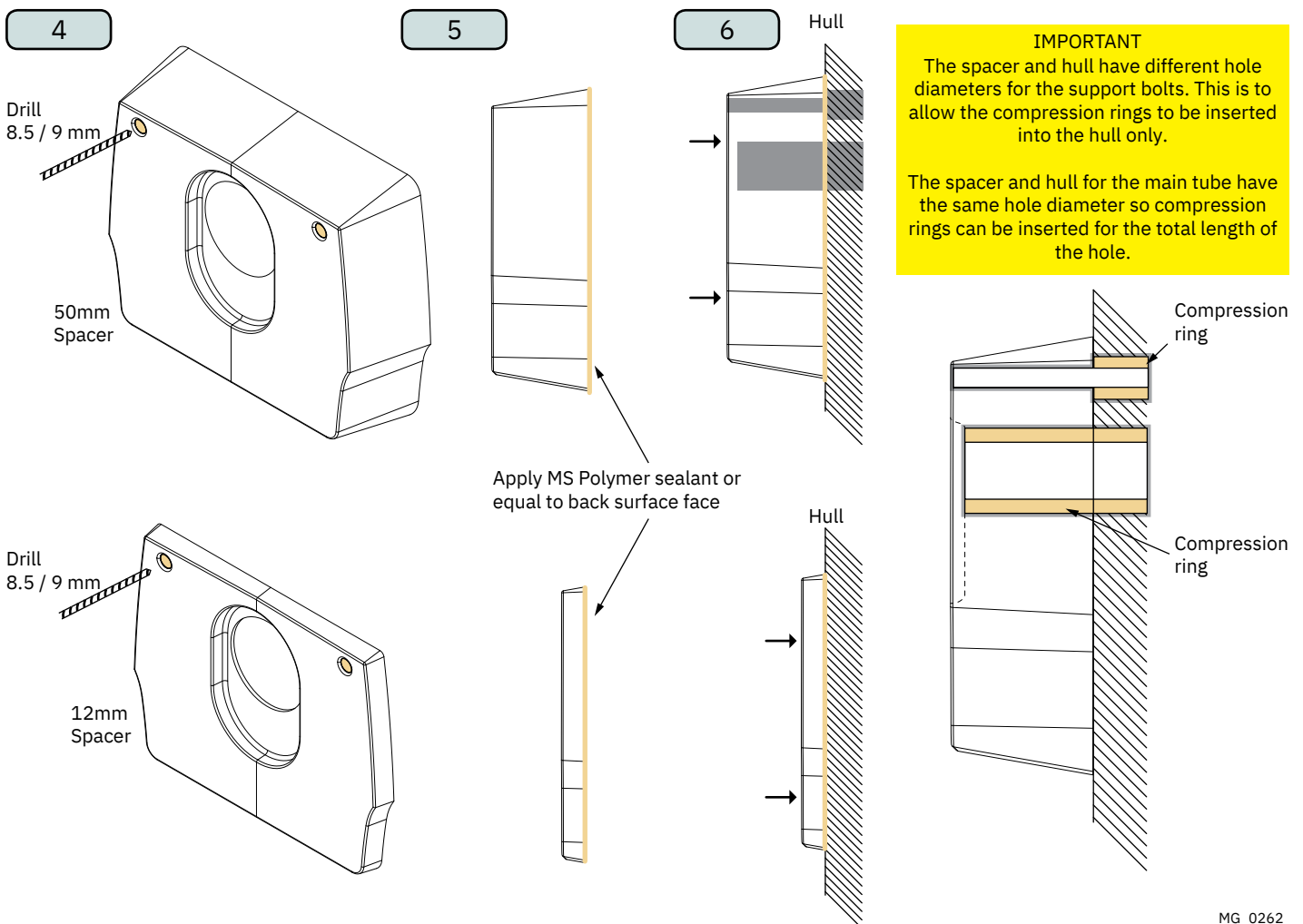

MG_0262

! Please refer to the graphic for special considerations relating to your model !

1. Define the location to install the thruster. **(NB: Ensure the thruster does not protrude past the transom profile on any side and there is no obstruction to the thrusters water flow. Also, check internally the thruster will not obstruct any objects. Ensure cables internally do not obstruct any objects. Do not place cables or control box close to high heat radiating parts EG. Turbo/ exhaust manifolds etc.)**
2. Mark the locations of the three drill holes using the defined measurements in this manual or from a template. **(NB: Maximum hull thickness is 50mm including optional spacer or 150mm for extended hull thickness models.)**
3. Drill main hole, then two support bolt holes. Clean the area from dust for installation of the thruster.
4. Install a bolt and washer to ensure top bolts contact surface area is level with the main tube. Temporarily place the thruster through the holes to ensure correct fitting. Using the cable leads from the thruster define the location within the vessel for the installation of the control box. **(NB: If using a spacer the support bolt and washer are not required.)**
5. Check the length of the compression rings. Compression rings must be longer than hull thickness to allow for compression **(NB: Cut compression sealants to length top achieve 10% compression.)**
6. The thruster assembly must sit flush on the transom. Grind and sand the area if required to ensure a secure fit. **(NB: Use caution when grinding/ sanding surfaces as to not remove too much fibreglass.)**
7. Ensure both bolts and washers to the support bars on the thruster are attached.
Apply a sealant (MS Polymer) to:
 - the inside surface of the cut-out holes on the hull.
 - To the surface of the washer to the thread and
 - in the recess of the main tube to the thread.
 - 1cm deep inside all compression ring.
 place all compression rings to bolt threads. **(NB: Ensure ample sealant (MS Polymer) around the bolts and centre tube for a watertight fitting.)**
8. Insert the thruster with compression rings into the hole.
9. Fasten the thruster

For installations in high corrosive environments (saltwater) the exposed aluminium parts of the thruster must be coated with an epoxy primer before antifouling or/and use.

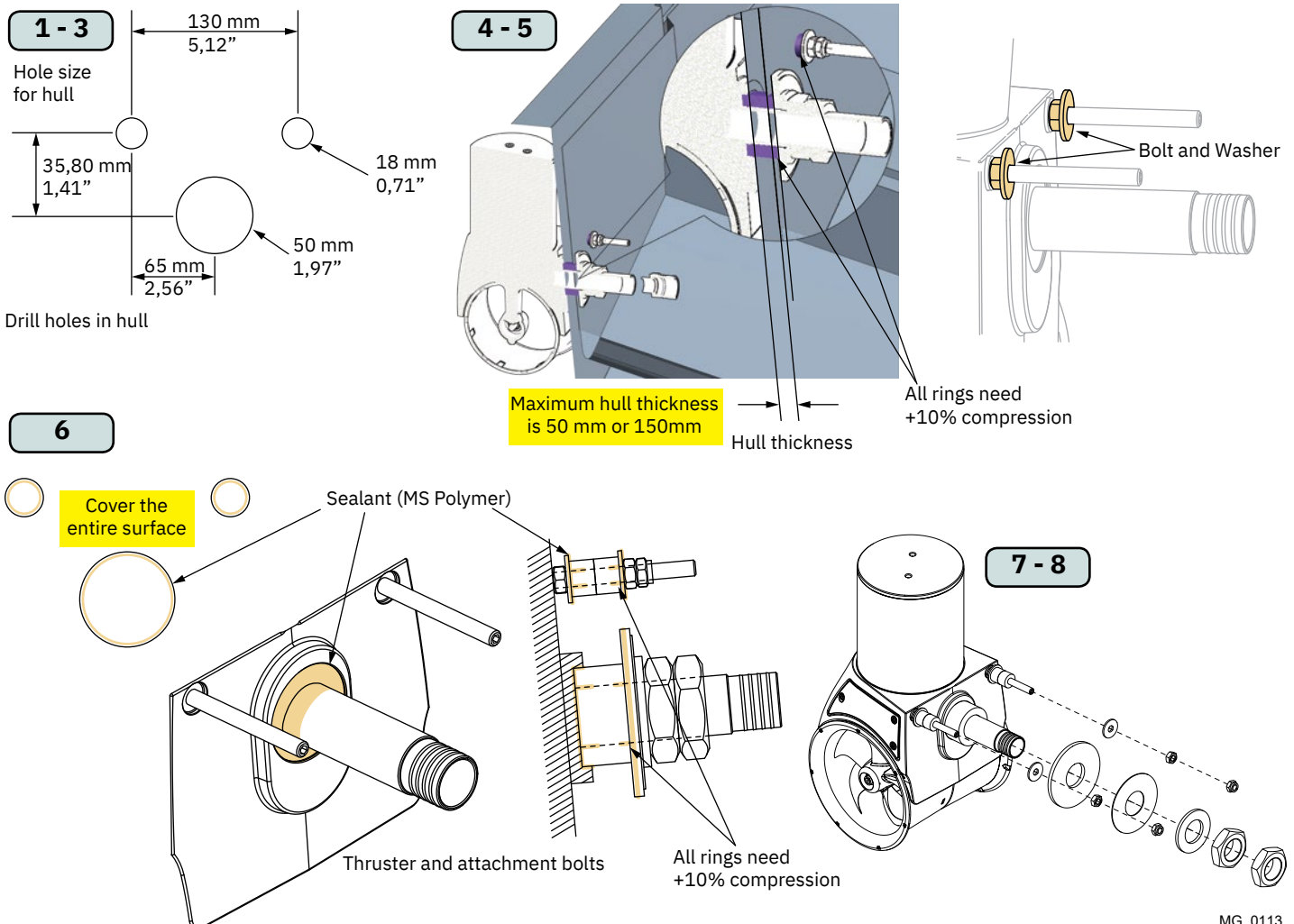

! Please refer to the graphic for special considerations relating to your model !

1. Centre the drive pin and Insert the propeller onto the shaft spline. Rotate the propeller until the drive pin aligns with the internal slot in the propeller.
2. Insert the washer to the end of the shaft spline. Tighten with the propeller lock-nut.
3. Apply anti fouling to the gear leg and propeller. Do not apply anti fouling to any rubber elements of the gear leg or anodes.

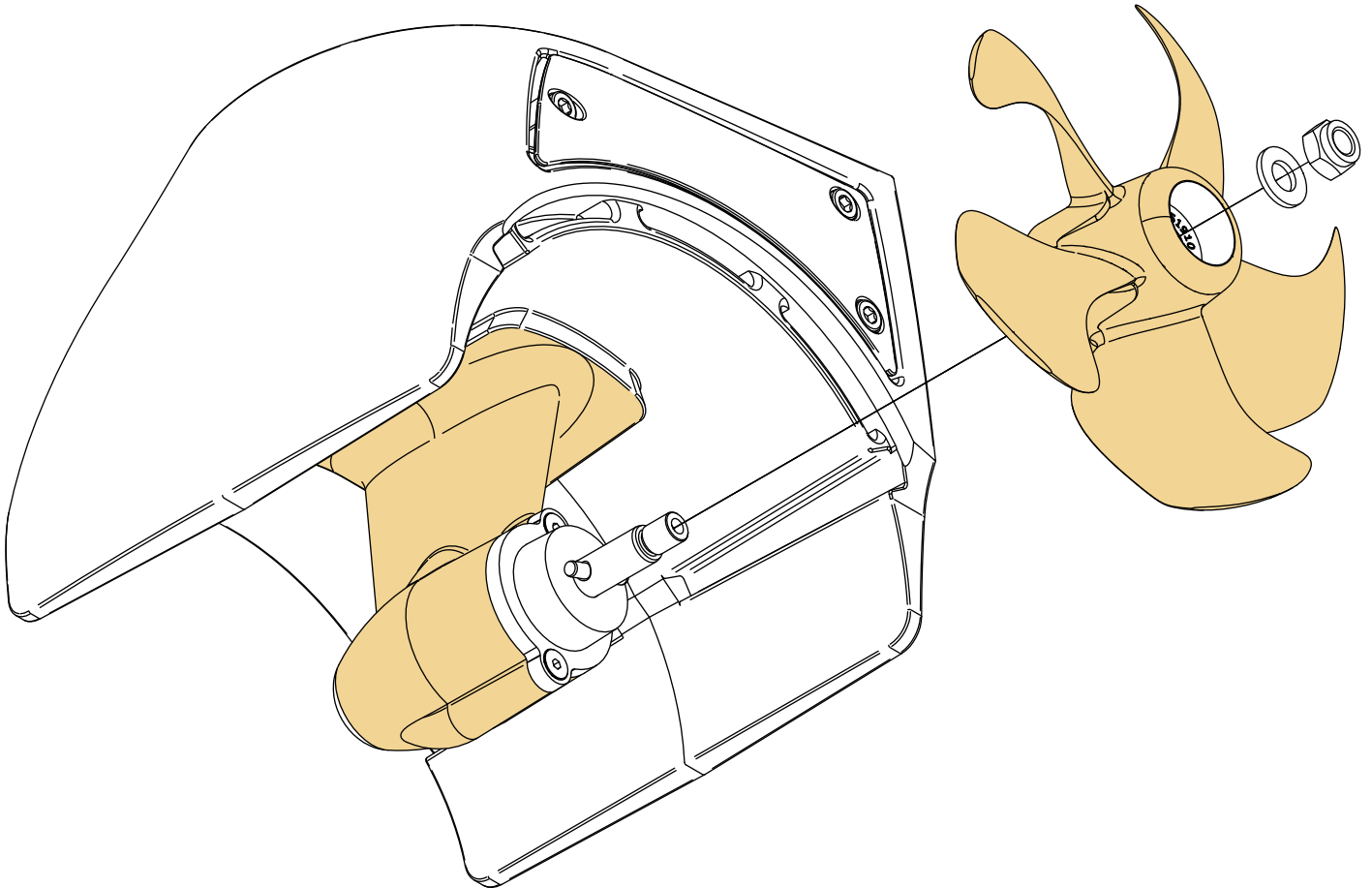

MG_0478

! Please refer to the graphic for special considerations relating to your model !

The control box is the central component that can be connected to several other control panels. The control box can be mounted in any orientation, preferably with cables facing down. **(NB: The control box must be positioned within 0,75 meters from the thruster assembly with the provided cables and not near any object that radiate high temperatures.)**

1. Define the location to install the control box. **(NB: Ensure cables will not obstruct any objects.)**
2. Mark the locations of the four drill holes and drill the holes.
3. Attach cables to the control box **(NB: the control box internal components can be removed via its attachment screws for easier installation using thick battery cables.)**
4. Tighten hose clamps in order to ensure Ignition Protection as illustrated.
5. Fasten the control box to the hull.

IMPORTANT

It is the installers full responsibility to follow instructions and ensure total Ignition Protection.

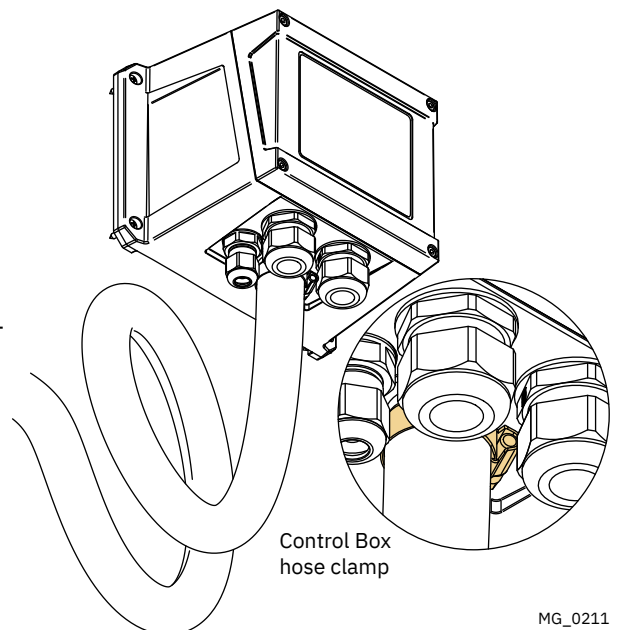
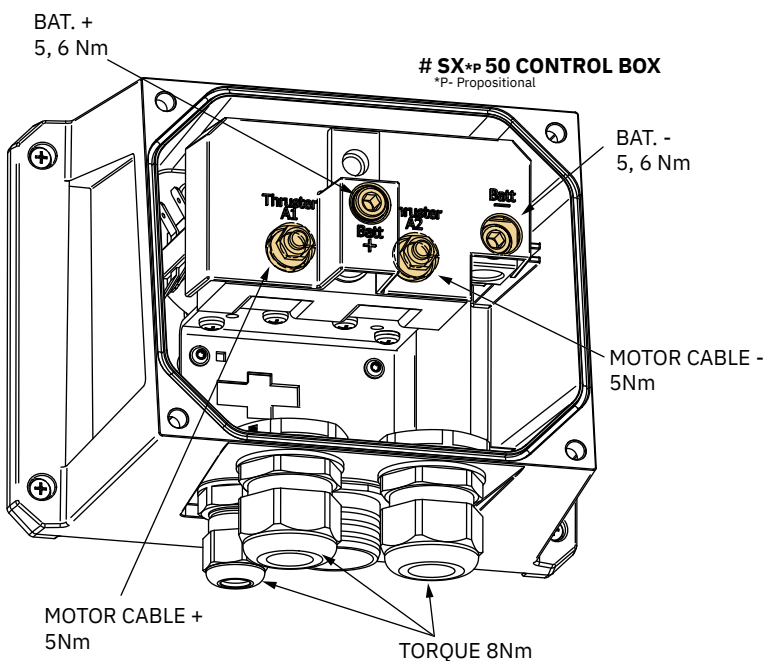
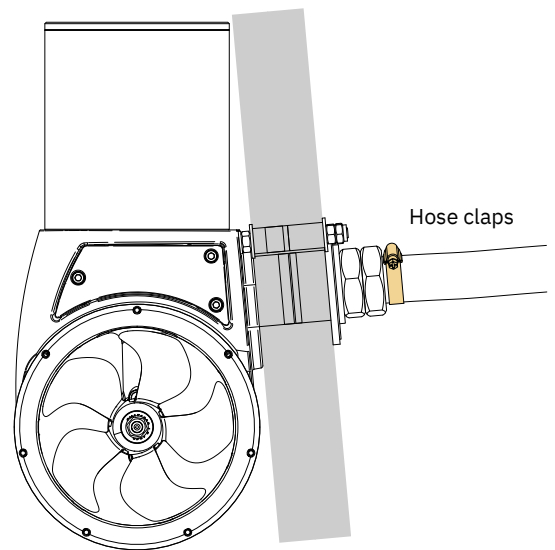
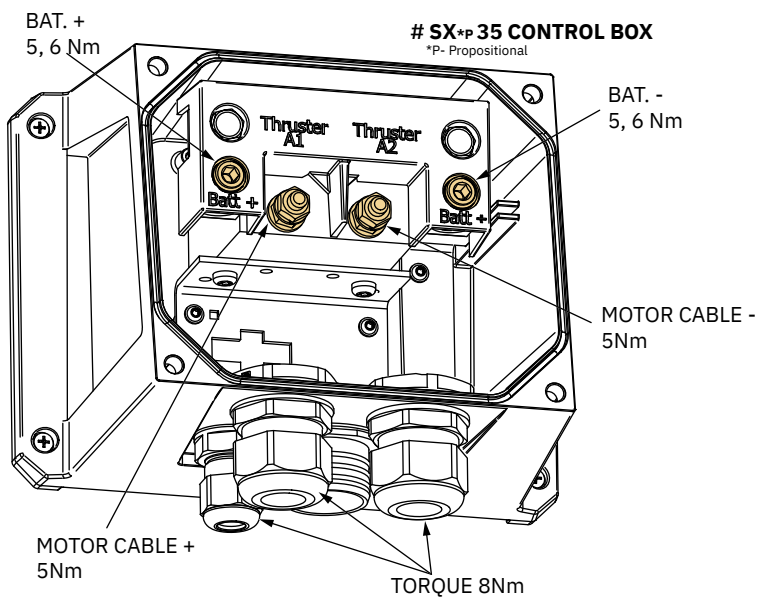

MG_0211

! Please refer to the graphic for special considerations relating to your model !

- Information of electrical table. *see next page*
 - All power cable lengths represent the total length of the combined (+) and (-) cables.
 - Battery capacity is stated as minimum cold crank capacity, (CCA).
 - Use slow blow rated fuses to hold stated Amp-Draw for min. 5 minutes.
 - Consider the AMP hours (Ah) for your specific duty cycle.
- Use appropriate sized cables and batteries with high cranking capacity to feed the thruster. The actual voltage at the motor while running the thruster decides the motors output RPM and thrust. Use larger cables and stronger batteries for better results.
 - See electrical specifications for advised minimum cables and batteries (CCA).
- Connect the battery supply to the control unit (PPC).
 - Install a main manual/ automatic switch from the positive lead terminal on the battery PPC unit). The main switch must be accessible to turn off the thruster independently from the rest of the electrical operation of the vessel when not on-board or in emergencies. **(NB: It is advised to install a fuse on the positive cable for protection against short-circuiting of the main cables. The fuse should ensure no voltage decrease, slow-blow and sized to take the amperage draw for at least 5 minutes.)**
 - A circuit breaker can be used instead of the fuse and main power switch If the functionality is the same.

(NB: For Ignition Protected installations remember to use ignition protected fuses and switches if fitted in areas that require this feature. Ensure to follow your national regulations)

- Cable lugs must have adequate electrical and mechanical isolation and fitted with cable lug covers.
- Fasten cables to the required torque.

WARNING
 Check the following with the main switch is set to off :
 After all electrical connections have been completed check with an ohm meter that there is no electrical connection between
 1. electro-motor flange and the positive terminal on the motor
 2. electro-motor flange and the battery negative terminal on the motor
 If unsure contact skilled personnel.

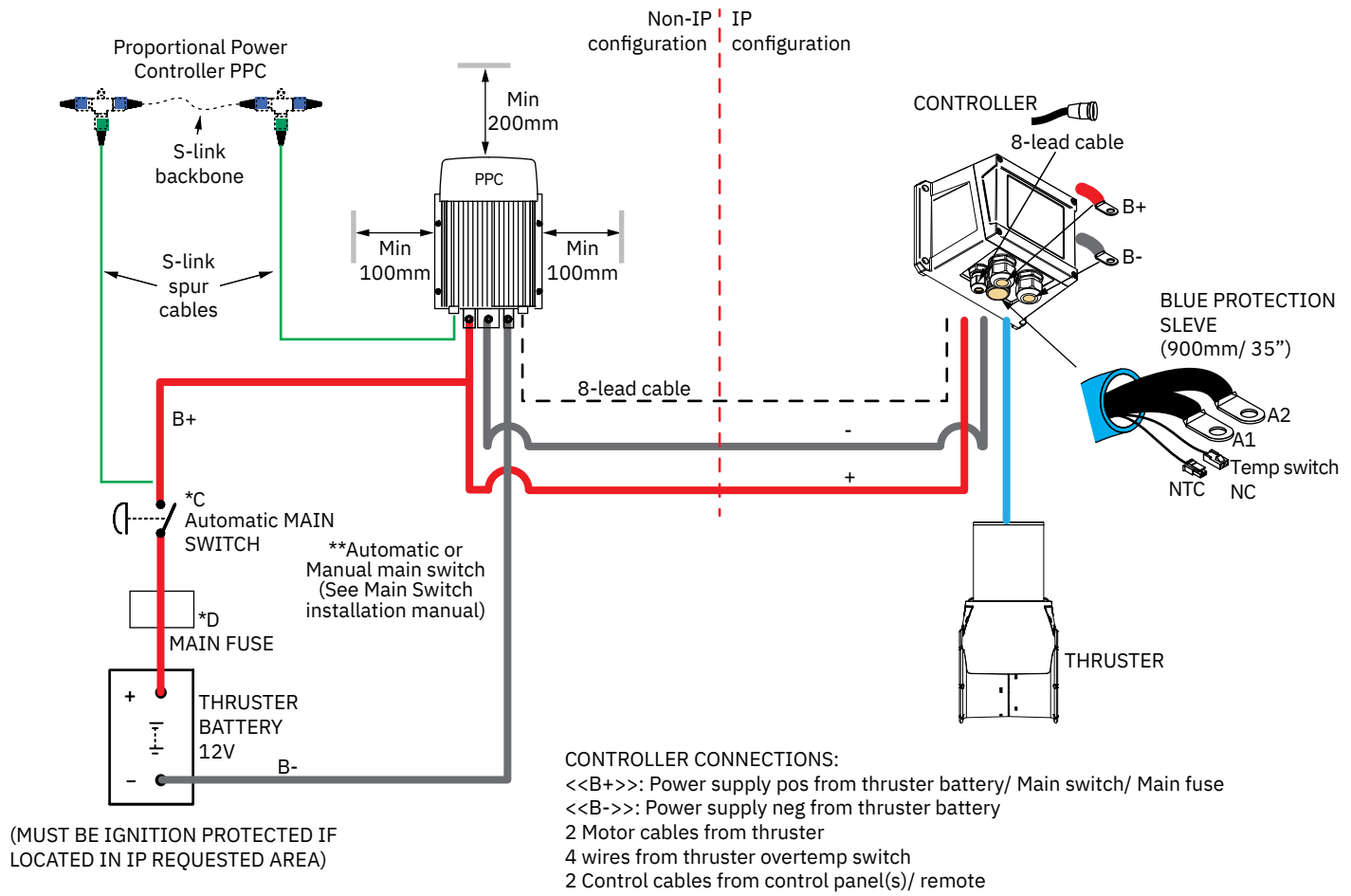

Minimum and recommended cable dimensions can be identical due to safety margins and cable heat considerations for short cable lengths.
 * Minimum or recommended cable cross section in mm²

Thruster Electrical Installation

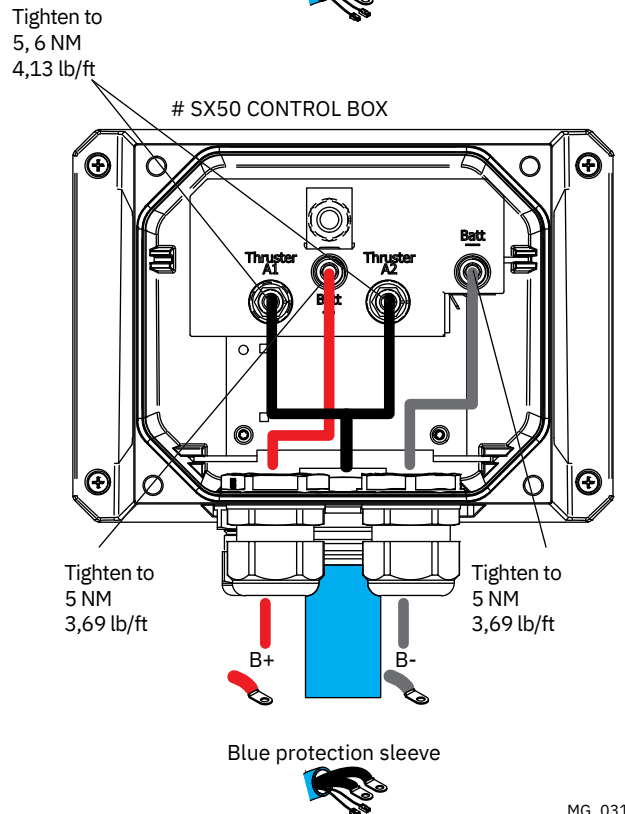
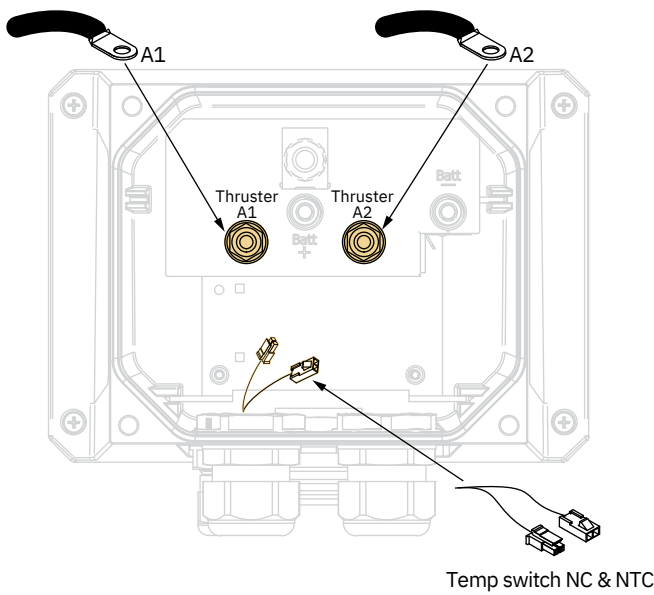
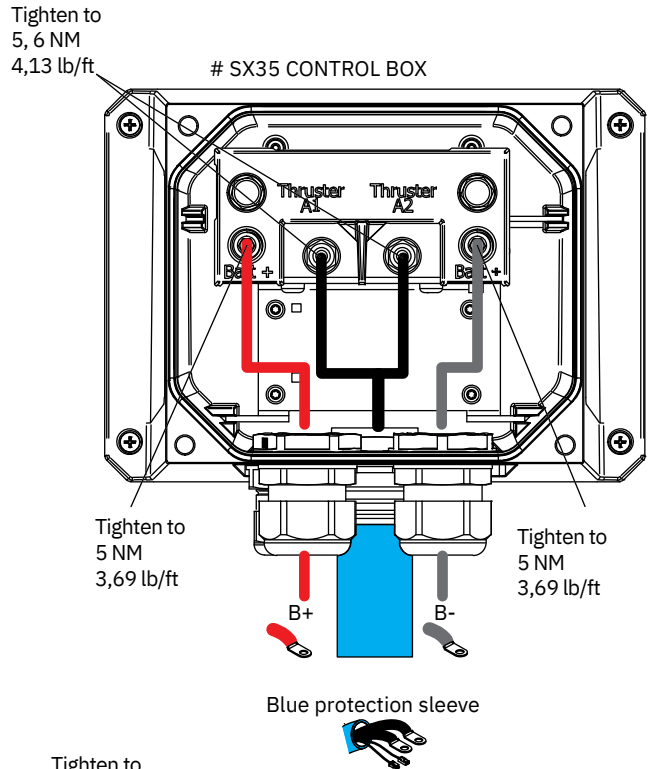
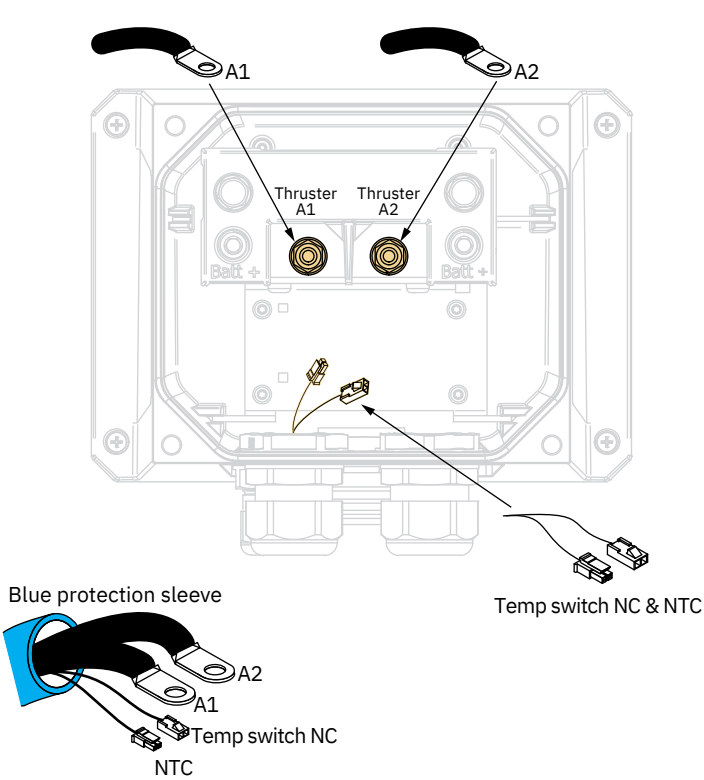
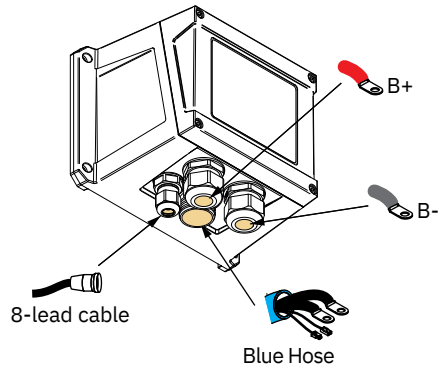

Model Size	System Voltage	Nominal current draw	Min. battery CCA	Rec. fuse	<7m total + & -		7-14m total + & -		15-21m total + & -		22-28m total + & -		28-35m total + & -		36-45m total + & -	
					Min.	Rec.	Min.	Rec.	Min.	Rec.	Min.	Rec.	Min.	Rec.	Min.	Rec.
					3	2	1/0	1/0	2/0	2/0	3/0	3/0	4/0	4/0	2 x 2/0	2 x 2/0
*35/140	12 V	245 A	DIN: 200 SAE: 380 EN: 330	ANL 150	mm2	50	70	70	95	120	120	120	120	120	2 x 70	2 x 95
					AWG	1/0	1/0	2/0	3/0	3/0	4/0	4/0	4/0	2 x 2/0	2 x 3/0	2 x 2/0
*50/1400	12 V	370 A	DIN: 350 SAE: 665 EN: 600	ANL 325	mm2	50	70	95	120	120	2 x 70	2 x 95	2 x 95	2 x 120	2 x 120	2 x 120
					AWG	1/0	2/0	3/0	4/0	4/0	2 x 2/0	2 x 3/0	2 x 3/0	2 x 4/0	2 x 4/0	2 x 4/0
24 V	170 A		DIN: 175 SAE: 332 EN: 280	ANL 150	mm2	25	25	35	50	50	35	50	50	70	70	70
					AWG	3	3	2	1/0	1/0	2	1/0	1/0	1/0	2/0	2/0

! Please refer to the graphic for special considerations relating to your model !

- All Sleipner control panels can be used in any combination.
- All control panels can be installed using:
 - Y-connectors - for standard on/off
 - T-connectors - for S-Link proportional power system.

(NB: If two or more control panels are operated at the same time in opposite directions, the electronic control box will stop the thruster until it receives a single signal or thrust in one direction.)

- Sleipner on/off equipment it is entirely “plug & play” and require no additional configuration setup.

See the Control panel manual for more information.

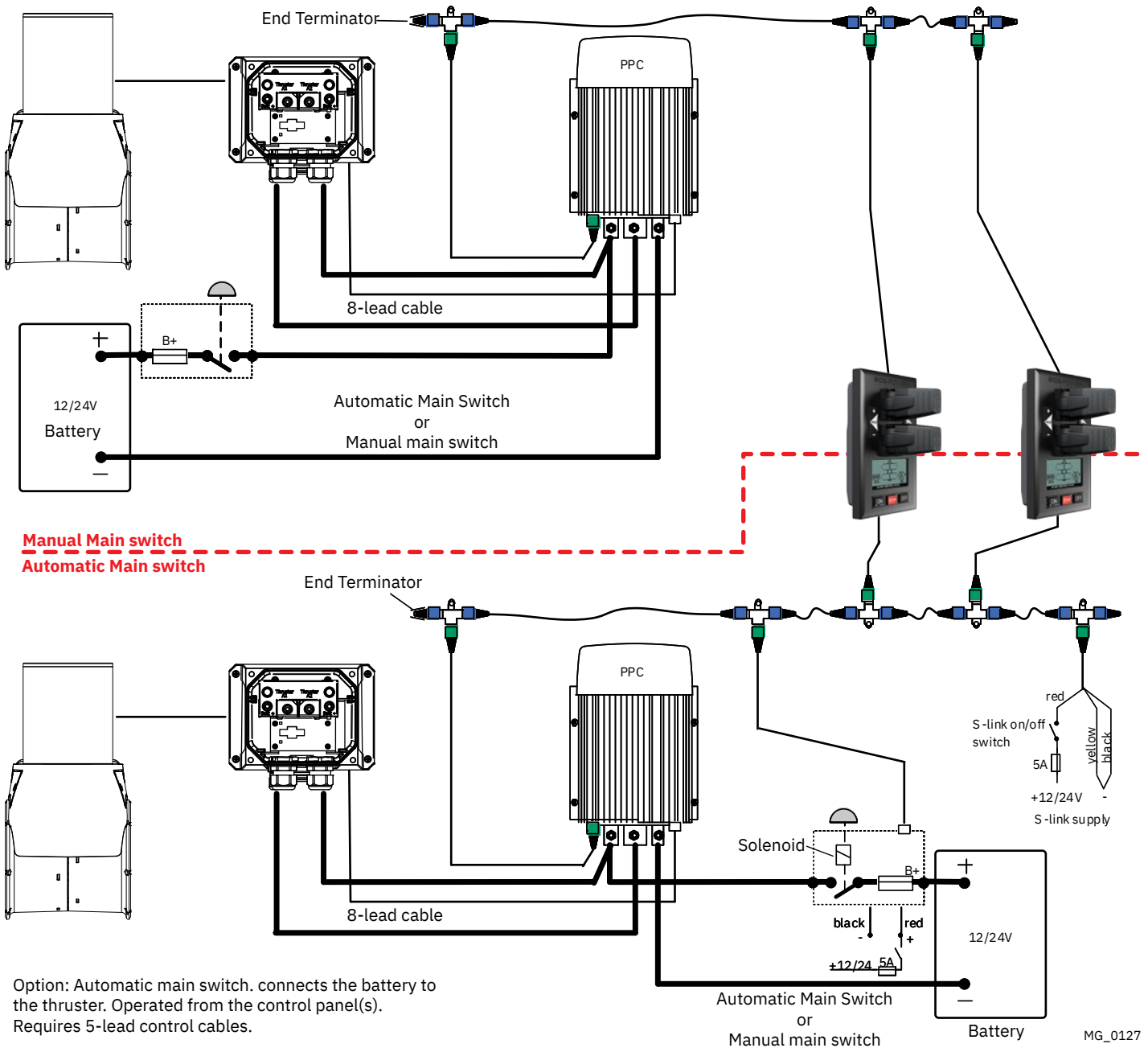

S-Link is a CAN-based control system used for communication between Sleipner products installed on a vessel. The system uses BACKBONE Cables as a common power and communication bus with separate SPUR Cables to each connected unit. Units with low power consumption are powered directly from the S-Link bus therefore one power cable must be connected to the BACKBONE Cable through a T-Connector. The S-Link cables should be installed such that sharp bend radius is avoided. Locking mechanism of connectors must be fully closed. Cables, T-Connectors and Extenders should not be located such that they are permanently immersed in water or other fluids.

Main advantages of S-Link system:

- Compact and waterproof plugs.
- BACKBONE and SPUR Cables have different colour coding and keying to ensure correct and easy installation. BACKBONE Cables have blue connectors and SPUR Cables have green connectors.
- Different cable lengths and BACKBONE Extenders makes the system scalable and flexible to install.

Installation of S-Link cables:

Select appropriate cables to keep the length of BACKBONE- and SPUR Cables to a minimum. The S-Link cables should be installed to ensure sharp bend radius's is avoided. The locking mechanism on connectors must be fully closed. Cables, T-Connectors and Extenders should not be located so that they are permanently immersed in water or other fluids.

The POWER Cable should ideally be connected around the middle of the BACKBONE Cable to ensure an equal voltage drop at each end of the BACKBONE Cable. The yellow and black wire in the POWER Cable shall be connected to GND and the red wire connected to +12VDC or +24VDC.

To reduce the risk of interference, avoid routing the S-Link cables close to equipment such as radio transmitters, antennas or high voltage cables. The backbone must be terminated at each end with the END Terminator.

Spur cables can be left unterminated to prepare for the installation of future additional equipment. In such cases, ensure to protect open connectors from water and moisture to avoid corrosion in the connectors.

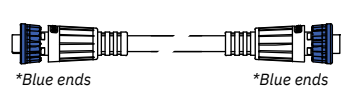

BACKBONE Cable
Forms the communication and power bus throughout a vessel. Available in different standard lengths.

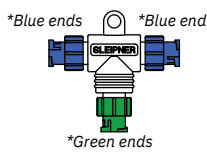

T-Connector
Used for connection of SPUR or POWER Cable to the BACKBONE Cable. One T-Connector for each connected cable.

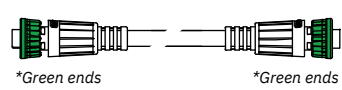

SPUR Cable
Used to connect S-Link compliant products to the backbone cable. One SPUR Cable must be used for each connected component, with no exceptions. Recommended to be as short as practically possible. Available in different standard lengths.

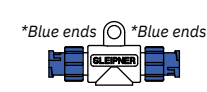

BACKBONE Extender
Connects two BACKBONE Cables to extend the length.

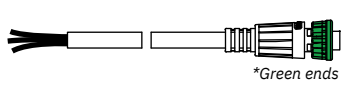

POWER Cable
Must be one in each system. Connects BACKBONE Cable to the power supply.

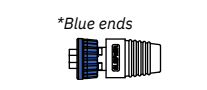

END Terminator
Must be one at each end of the BACKBONE bus.

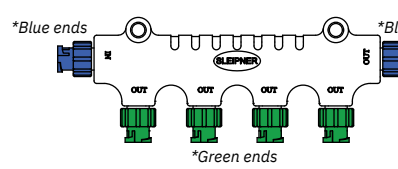

4-Port T-Connector
The 4-PORT T-connector allows multiple SPUR Cables to be connected. The 4-PORT T-connector comes with two sealing caps to protect unused ports.

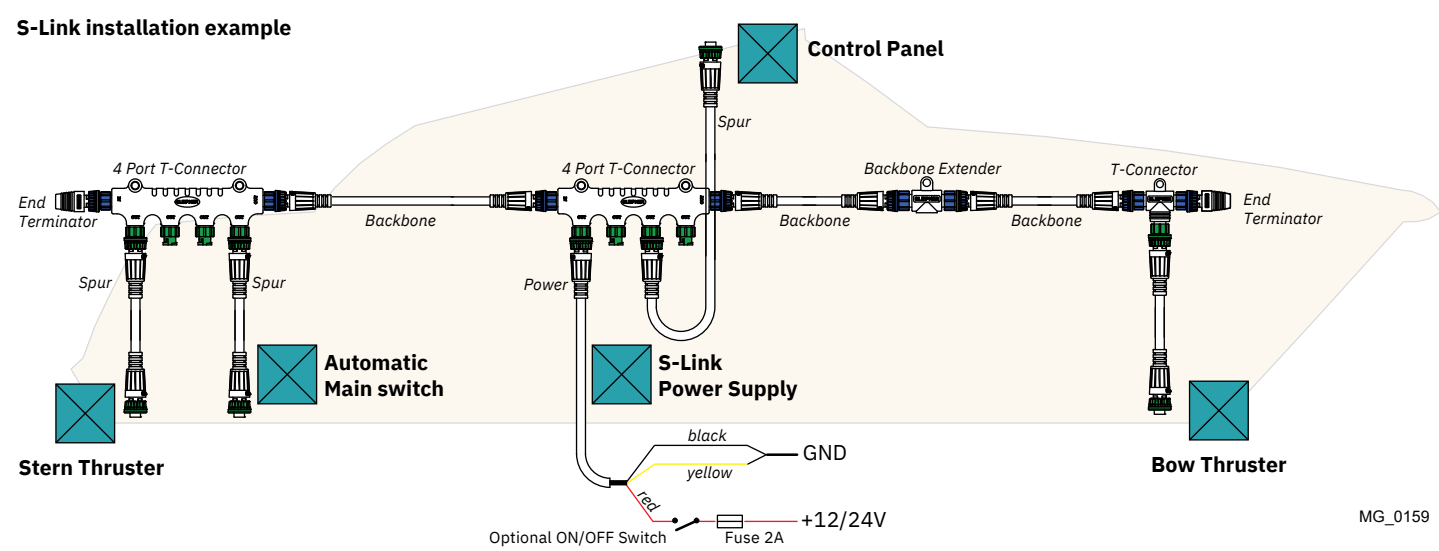

For **Control Panel** installation please refer to the supplied manual in your Sleipner product delivery



- Propeller is fastened correctly to the shaft.
- Propeller turns freely in tunnel.
- Primer and anti-fouling have been applied to the gear house and propeller but NOT on the anode or the gear house lid where the propeller is fastened.
- Correct drive direction as per control panel.
- The bolts holding the thruster are tightened correctly.
- The bolts holding the motor to its bracket are tightened correctly.
- All electrical connections are clean, dry and tight, and the correct cable, fuse and main switch size.
- No water leakage around hull penetrated studs
- Check that there is no electrical connection between the electro motor body and positive terminal on the motor, and between the electro motor body and the negative (A1) terminal on the motor with an ohm meter.

The thruster has been installed as per the instructions in this manual and all points in checklist above have been controlled.

Signed:

Date:

Extra pre-delivery tests by installer / yard who does not use other quality control systems !

Thruster type:

Serial number:.....

Date of delivery:.....

Correct drive direction as per control panel:

The compartment for the thruster has been isolated from general bilge water and has no obvious or suspected risks for flooding:

.....
.....
.....

Other comments by installer:

.....
.....
.....

Find your local professional dealer from our certified worldwide network for expert service and support.

visit our website www.sleipnergrou.com/support

Product Spare Parts and Additional Resources

For additional supporting documentation, we advise you to visit our website www.sleipnergrou.com and find your Sleipner product.

Warranty statement

1. Sleipner Motor AS (The "Warrantor") warrants that the equipment (parts, materials and embedded software of products) manufactured by the Warrantor is free from defects in workmanship and materials for the purpose for which the equipment is intended and under normal use and service (the "Warranty").
2. This Warranty is in effect for two years (Leisure Use) or one year (Commercial and other Non-leisure Use) from the date of purchase by the end user (for demonstration vessels, the dealer is deemed as end user).
3. This Warranty is transferable and covers the equipment for the specified warranty period.
4. The warranty does not apply to defects or damages caused by faulty installation or hook-up, abuse or misuse of the equipment including exposure to excessive heat, salt or fresh water spray, or water immersion except for equipment specifically designed as waterproof.
5. In case the equipment seems to be defective, the warranty holder (the "Claimant") must do the following to make a claim:
 - (a) Contact the dealer or service centre where the equipment was purchased and make the claim. Alternatively, the Claimant can make the claim to a dealer or service centre found at www.sleipnergrou.com. The Claimant must present a detailed written statement of the nature and circumstances of the defect, to the best of the Claimant's knowledge, including product identification and serial nbr., the date and place of purchase and the name and address of the installer. Proof of purchase date should be included with the claim, to verify that the warranty period has not expired;
 - (b) Make the equipment available for troubleshooting and repair, with direct and workable access, including dismantling of furnishings or similar, if any, either at the premises of the Warrantor or an authorised service representative approved by the Warrantor. Equipment can only be returned to the Warrantor or an authorised service representative for repair following a pre-approval by the Warrantor's Help Desk and if so, with the Return Authorisation Number visible postage/shipping prepaid and at the expense of the Claimant.
6. Examination and handling of the warranty claim:
 - (a) If upon the Warrantor's or authorised service Representative's examination, the defect is determined to result from defective material or workmanship in the warranty period, the equipment will be repaired or replaced at the Warrantor's option without charge, and returned to the Purchaser at the Warrantor's expense. If, on the other hand, the claim is determined to result from circumstances such as described in section 4 above or a result of wear and tear exceeding that for which the equipment is intended (e.g. commercial use of equipment intended for leisure use), the costs for the troubleshooting and repair shall be borne by the Claimant;
 - (b) No refund of the purchase price will be granted to the Claimant, unless the Warrantor is unable to remedy the defect after having a reasonable number of opportunities to do so. In the event that attempts to remedy the defect have failed, the Claimant may claim a refund of the purchase price, provided that the Claimant submits a statement in writing from a professional boating equipment supplier that the installation instructions of the Installation and Operation Manual have been complied with and that the defect remains.
7. Warranty service shall be performed only by the Warrantor, or an authorised service representative, and any attempt to remedy the defect by anyone else shall render this warranty void.
8. No other warranty is given beyond those described above, implied or otherwise, including any implied warranty of merchantability, fitness for a particular purpose other than the purpose for which the equipment is intended, and any other obligations on the part of the Warrantor or its employees and representatives.
9. There shall be no responsibility or liability whatsoever on the part of the Warrantor or its employees and representatives based on this Warranty for injury to any person or persons, or damage to property, loss of income or profit, or any other incidental, consequential or resulting damage or cost claimed to have been incurred through the use or sale of the equipment, including any possible failure or malfunction of the equipment or damages arising from collision with other vessels or objects.
10. This warranty gives you specific legal rights, and you may also have other rights which vary from country to country.

Patents

At Sleipner we continually reinvest to develop and offer the latest technology in marine advancements. To see the many unique designs we have patented visit our website www.sleipnergrou.com/patents

© Copyright Sleipner Motor AS, 2021

The information given in the document was correct at the time it was published.

However, Sleipner Motor AS can not accept liability for any inaccuracies or omissions it may contain. Continuous product improvement may change the product specifications without notice.

Therefore, Sleipner Motor AS can not accept liability for any possible differences between product and document.

Register your product and learn more at www.sleipnergroun.com



SLEIPNER AS

P.O. Box 519

N-1612 Fredrikstad

Norway

www.sleipnergroun.com

Made in Norway





SLEIPNER

Ocean born. Tech bred.

User Manual

Keep this
manual onboard!

SXP SERIES

THRUSTER USER MANUAL

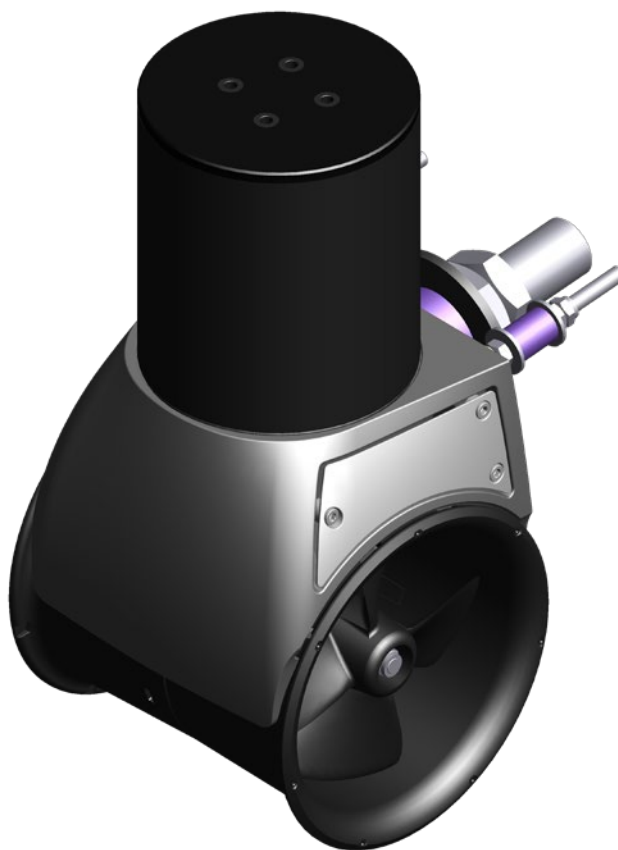

SLEIPNER AS

P.O. Box 519

N-1612 Fredrikstad

Norway

www.sleipnergroupp.com

Document id: 5925

Revision: 8

Date: 2021



Made in Norway

© Sleipner Motor AS 2021

Product Information

User Considerations and Precautions	3
Thruster Operation	4
Control Panel	5
Proportional Thruster Display	6
Proportional Thruster Display Symbols	7
HOLD Function	8
Calibration.....	8
Warning Signals When Using 'HOLD' Function	8
MENU System	9
Alarm Descriptions	10 - 11
PHC-3 Alarm Descriptions.....	12 - 13
PDC-301 Alarm Descriptions	13
Maintenance	14- 15
Troubleshooting - DC series	16
Seasonal Checklist.....	17

Spare Parts	18
--------------------------	-----------

Warranty statement	18
---------------------------------	-----------

Products

SXP50/140-12V-150MM - SXP50/140 w/Controller and PPC
 SXP50/140-12V-50MM - SXP50/140 w/Controller and PPC
 SXP35/140-12V-50MM - SXP35/140 w/Controller and PPC
 SXP35/140-12V-150MM - SXP35/140 w/Controller and PPC

DECLARATION OF CONFORMITY

MC_0020



Sleipner Motor AS
 P.O. Box 519, Arne Svendsensgt. 6-8
 N-1612 Fredrikstad, Norway

Declare that this product with accompanying standard control systems
 complies with the essential health and safety requirements according to:

DIRECTIVE 2013/53/EU
 DIRECTIVE 2014/30/EU
 DIRECTIVE 2014/35/EU

IMPORTANT

Failure to follow the Considerations and precautions can cause serious injury / damage and will render all warranty given by Sleipner Motor AS VOID.

Never use thrusters when close to objects/ persons or pets in the water. The thruster will draw objects into the tunnel and the rotating propellers. This will cause serious injuries and damage the thruster.

Always turn the main power switch off before touching any part of the thruster, An incidental start while touching moving parts can cause serious injuries.

- Ensure you know the location of the main battery switch that disconnects the thruster from all power sources (batteries) so the thruster can be turned off in case of serious malfunction.
- Always turn the control device off when the thruster is not in use or when leaving the boat.
- When leaving the boat always turn off the main power switch for the thruster.
- The maximum continuous run time of the electrical thruster is approximately 3 minutes. The motor is equipped with a built-in thermal cut-off switch that will shut the motor off when overheating. Consider this when planning your manoeuvring.
- Never use thrusters out of water.
- If the thruster stops giving thrust while running, there is possibly a problem in the drive system. You must immediately stop running the thruster and turn it off. Running the thruster for more than a few seconds without resistance from the propeller can cause serious damage to the thruster.
- We advise keeping the main engine(s) running while using the thruster. This will keep the batteries in a good charge condition. It will also give better performance to the thruster, a higher voltage at the thruster results in a higher torque (power) in the electro motor.
- If the performance of the thruster is reduced check the battery system.
- If two panels are operated with conflicting directions at the same time the thruster will not run. If both are operated in the same direction, the thruster will run in this direction.
- If you notice any faults with the thruster switch it off to avoid further damage.
- The contacts/ plugs or other joints in the control cables must be mounted so they will remain dry at all times.
- It is the owner/ captain/ other responsible parties full responsibility to assess the risk of any unexpected incidents on the vessel. If the thruster stops giving thrust for some reason while manoeuvring you must have considered a plan on how to avoid damage to persons or other objects.
- The primary purpose of the thruster is to manoeuvre/ dock the vessel. Forward/ reverse speed must not exceed 4 knots when operated.

IMPORTANT

NEVER Disassemble any part of the Ignition Protected assembly. Tampering with the Ignition Protected assembly will cause it to lose this safety feature.

If there is a problem with your Ignition Protected stern thruster, please contact your dealer.

! Please refer to the graphic for special considerations relating to your model !

Take time to practice operation in open water to become familiar with the thruster and to avoid damages to your boat or people.

How to use the Thruster

1. Turn on the main power switch for the thruster. **(NB: Always turn off the main power switch when not on-board.)**
2. Turn on the control panel by pushing both "ON" buttons on the Sleipner panel simultaneously.
* Turn off the control panel by pushing both "OFF" button

(NB: Control panels designed for the hydraulic system have a replace the secondary 'OFF' button with a red 'STOP' button for an emergency stop function.)

Joystick Control

To Turn the bow in the desired direction move the joystick in the direction you wish the bow to move.

Button Control

For 'HOLD' function.

* For other controls like foot switches or toggle-switches please refer to that products user manual for detailed operational use.

How to use a combined bow and stern thruster

The combination of a bow and stern thruster offers total manoeuvrability to the boat and the ability to move the bow and the stern separately from each other. This enables you to move the boat sideways in both directions and turn the boat around its axis 360° staying stationary.

(NB: At speed the side thruster will have little or no effect to steer the vessel.)

Proportional control thruster

For proportional control move the joystick equivalent to the amount of thrust you intend to receive.

PRO proportional CONTROL PANEL



PJC211

PJC212

S-Link REMOTE CONTROL



RCS-20

Proportional Control Panel

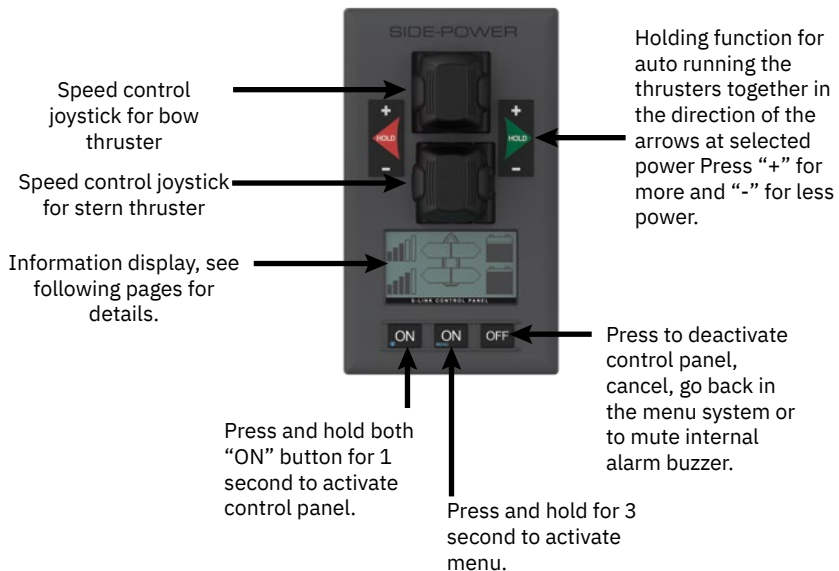

Activating the bow thruster



*Control panel example



Activating the stern thruster



*Control panel example

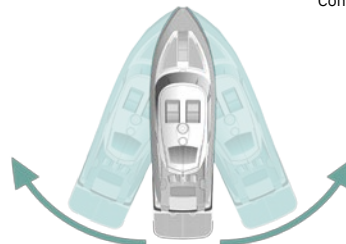

Activating both bow and stern thruster to push the boat sideways

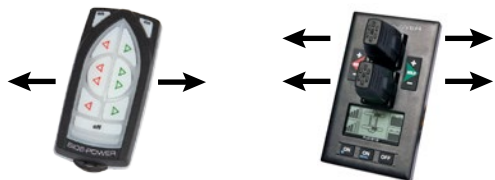

*Control panel example

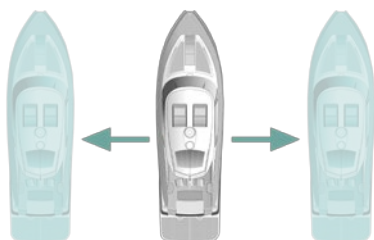

Activating both bow and stern thruster to rotate the boat on axis



*Control panel example

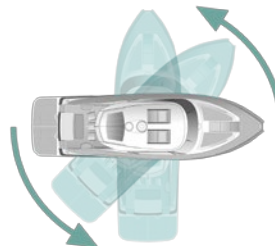

As a part of the seasonal service of your Thruster before every season, always check that:

In Water

- The area around cables inside the boat are clean and dry. Ensure there are no signs of water leakage in the area.
- All electrical connections are clean and fastened firmly.
- Ensure that your batteries are in good condition.

Out of Water

- Check the propeller(s) or tunnel for any damage for example impact damage.
- The propeller(s) is fastened securely to the gear leg.
- Paint the propeller and gear leg with anti-fouling before every season to keep it clean from sea growth. **(NB: Never paint the anode, sealing or propeller shaft. Ensure paint does not enter the space between the propeller and the gear leg.)**
- Change the anode before every season, or when half the anode has eroded. Always use a sealant or thread glue on the holding screw to ensure that it does not fall off.

IMPORTANT

NEVER Disassemble any part of the Ignition Protected assembly. Tampering with the Ignition Protected assembly will cause it to lose this safety feature.

If there is a problem with your Ignition Protected stern thruster, please contact your dealer.

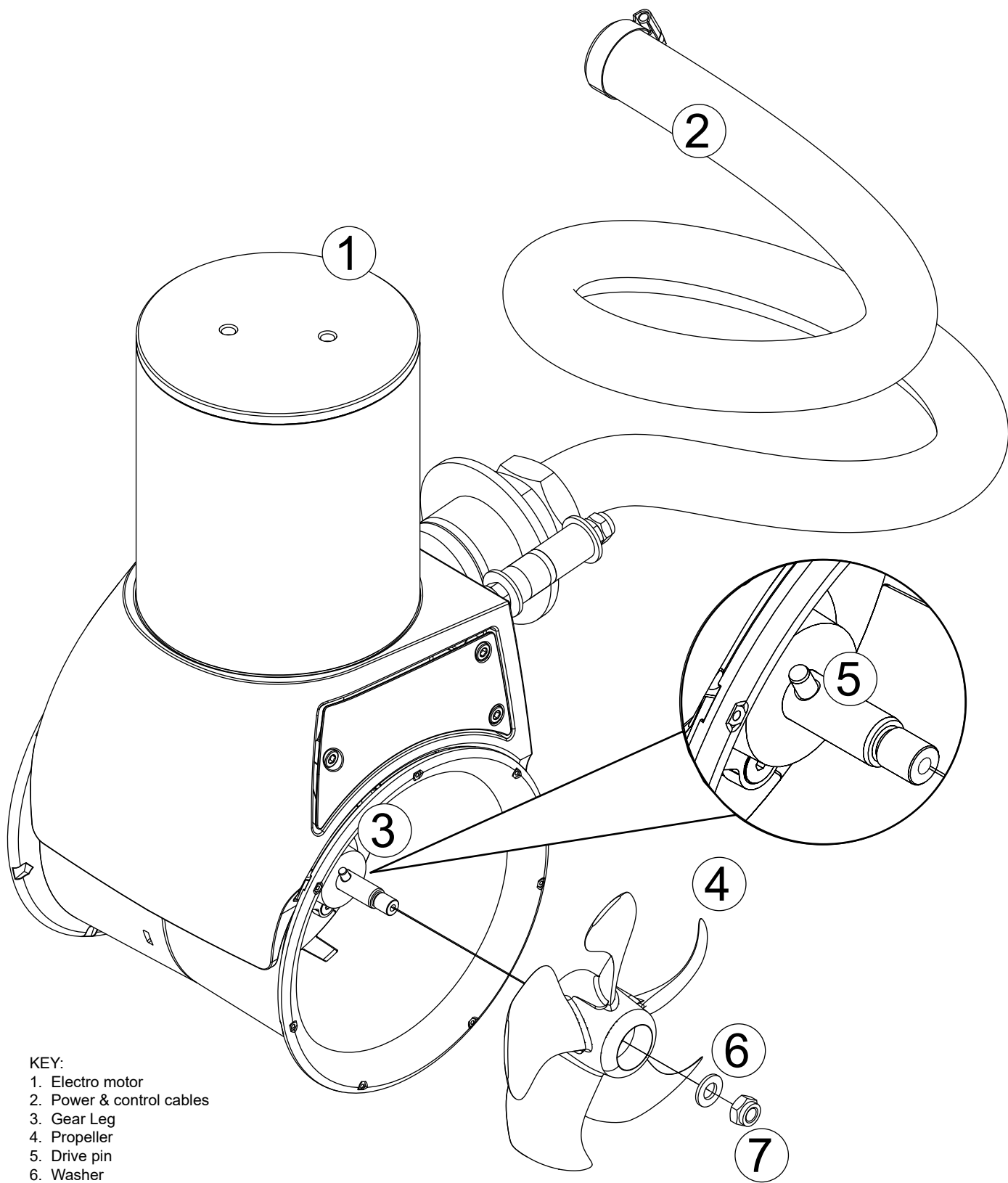

KEY:

- 1. Electro motor
- 2. Power & control cables
- 3. Gear Leg
- 4. Propeller
- 5. Drive pin
- 6. Washer
- 7. Lock Nut

Before seeking assistance from the website help desk from your Sleipner dealer/ distributor, please perform these tests.

(NB: If you are unable to understand what to check, you must consult a Sleipner distributor.)

Control panels operating on the S-link system display all faults via the control panel interface or via other warning methods.

To review any issues of your product refer to the appropriate user manual for a complete list of fault codes and troubleshooting guides.

For additional supporting documentation, we advise you to visit our website www.sleipnergroun.com for the spare parts list.



CHECK TO PERFORM	DATE											
The SX unit is fastened securely to the hull.												
Bolts holding the SX components are fastened securely.												
Paint the SX unit with anti-fouling.												
Batteries are in good condition.												
All electrical connections are clean and fastened firmly.												

For the most up to date documentation, we advise you to visit our website www.sleipnergrouper.com for the spare parts list.

For additional supporting documentation, we advise you to visit our website www.sleipnergrouper.com.

1. The equipment manufactured by Sleipner Motor AS (The "Warrantor") is warranted to be free from defects in workmanship and materials under normal use and service.
2. This Warranty is in effect for of two years (Leisure Use) or one year (Commercial use) from the date of purchase by the user. Proof of purchase must be included, to establish that it is inside the warranty period.
3. This Warranty is transferable and covers the product for the specified time period.
4. In case any part of the equipment proves to be defective, other than those parts excluded in paragraph 5 below, the owner should do the following:
 - (a) Prepare a detailed written statement of the nature and circumstances of the defect, to the best of the Owner's knowledge, including the date of purchase, the place of purchase, the name and address of the installer, and the Purchaser's name, address and telephone number;
 - (b) The Owner should return the defective part or unit along with the statement referenced in the preceding paragraph to the warrantor, Sleipner Motor AS or an authorized Service Centre, postage/shipping prepaid and at the expense of the Purchaser;
 - (c) If upon the Warrantor's or Authorized Service Centre's examination, the defect is determined to result from defective material or workmanship, the equipment will be repaired or replaced at the Warrantor's option without charge, and returned to the Purchaser at the Warrantor's expense;
 - (d) no refund of the purchase price will be granted to the Purchaser, unless the Warrantor is unable to remedy the defect after having a reasonable number of opportunities to do so. Prior to refund of the purchase price, Purchaser must submit a statement in writing from a professional boating equipment supplier that the installation instructions of the Installation and Operation Manual have been complied with and that the defect remains;
 - (e) warranty service shall be performed only by the Warrantor, or an authorized Service Centre, and any attempt to remedy the defect by anyone else shall render this warranty void.
5. There shall be no warranty for defects or damages caused by faulty installation or hook-up, abuse or misuse of the equipment including exposure to excessive heat, salt or fresh water spray, or water immersion except for equipment specifically designed as waterproof.
6. No other express warranty is hereby given and there are no warranties which extend beyond those described in section 4 above. This Warranty is expressly in lieu of any other expressed or implied warranties, including any implied warranty of merchantability, fitness for the ordinary purposes for which such goods are used, or fitness for a particular purpose, and any other obligations on the part of the Warrantor or its employees and representatives.
7. There shall be no responsibility or liability whatsoever on the part of the Warrantor or its employees and representatives for injury to any person or persons, or damage to property, loss of income or profit, or any other consequential or resulting damage or cost which may be claimed to have been incurred through the use or sale of the equipment, including any possible failure or malfunction of the equipment, or part thereof.
8. The Warrantor assumes no liability for incidental or consequential damages of any kind including damages arising from collision with other vessels or objects.
9. This warranty gives you specific legal rights, and you may also have other rights which vary from country to country.

www.sleipnergroun.com



SLEIPNER AS * AS P.O. Box 519 * N-1612 Fredrikstad * Norway

The information given in the document was correct at the time it was published. However, Sleipner Motor AS can not accept liability for any inaccuracies or omissions it may contain. Continuous product improvement may change the product specifications without notice. Therefore, Sleipner Motor AS can not accept liability for any possible differences between product and document.

MC_0030