

WATERPROOF 2 WAY STEREO SPEAKERS



MARINE STEREO SPEAKERS

Ø165mm. / Watt power: 60 (pair)



RMS 2 x 15W 12V Bluetooth Amplifier

When powering on the amplifier, while it is connected to a speaker, you will hear a tone which confirms the device is on.

To connect a Bluetooth device, search for the device name IMNASA and use the password located at the bottom of the sheet to connect.

When playing music, the Bluetooth audio input will take priority over the analog input located on the device. This means if the analog input is being used, and a Bluetooth device is connected, the amplifier will then use the Bluetooth device as the source. If the Bluetooth device is disconnected, and the analog device is still connected, the amplifier will then use the analog device as the source.

Bluetooth Connection Diagram

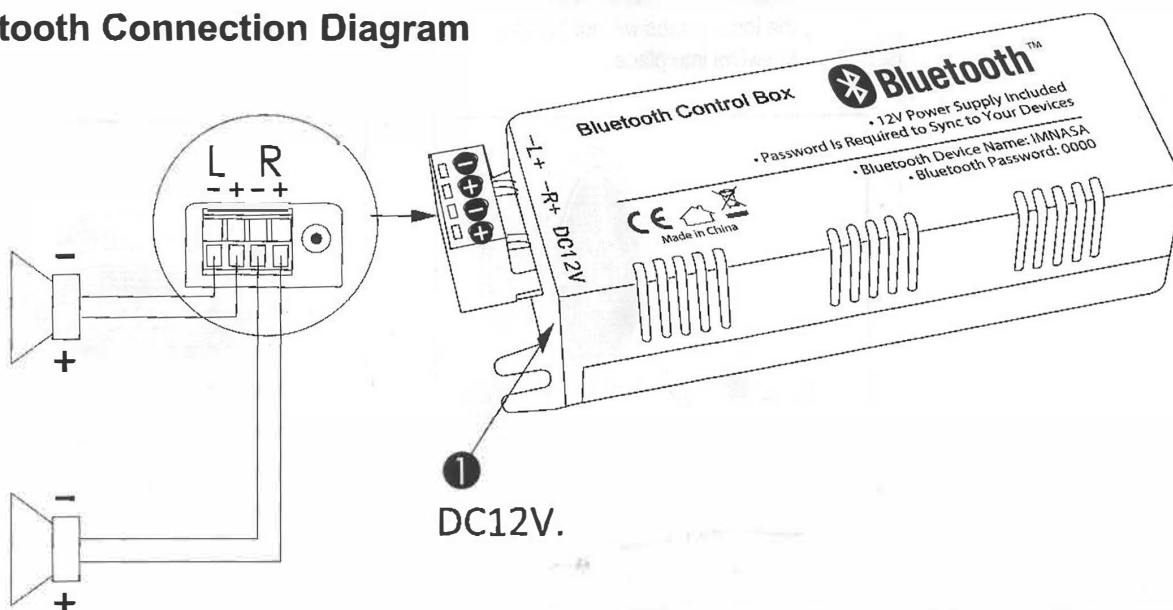

Bluetooth Device Name: IMNASA
Bluetooth Password: 0000