

LUX Light Control Module Installation Guide

Please read the following pages before attempting installation to ensure complete understanding of the LUMISHORE LUX Light Control Module



Before you start...

- Always ensure that the vessel's power source and battery are disconnected or isolated prior to installation.
- A qualified professional should carry out both the electrical and mechanical installation.
- The Lux Light module should be mounted on a flat surface and in a cool, dry, well ventilated location.
- Each Lux Light Module should be individually fused and/or connected to a suitable circuit breaker.
- The Lux Light Module is designed to work with a number of Lumishore Lux Lighting products (Downlights, Courtesy Lights etc...), do not use with other lighting brands, this will invalidate the warranty.
- Connect each Light to the Light module using standard 3-core cable (see wiring diagram on the following pages). Calculate the current draw for the system at the vessels input voltage. Ensure the correct cable gauge is used to avoid issues with voltage drop. Follow ABYC recommendations for no more than 3% voltage drop at 12V, and 10% voltage drop at 24V.

Basic Dimensions:

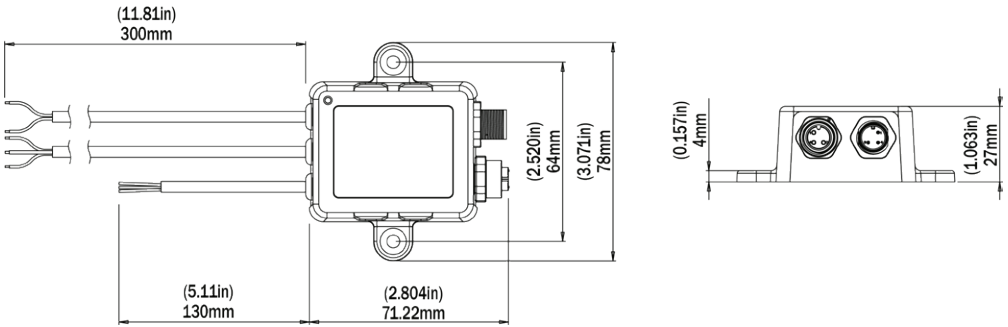

Electrical specification:

- Input = 10.5 to 31 Volt
- Output = 10.5 to 31 volts
- Max Lights on one module = 16
- Typical current draw @ MAX 16 lights = 9.6Amps@12V, 4.8Amps@24V

Fuse rating (Note: Each Light Module should be connected via an inline fuse or circuit breaker)

To choose the correct fuse rating, check the current draw of the Light being used and multiply by the number of lights attached.

Input & Output connections:

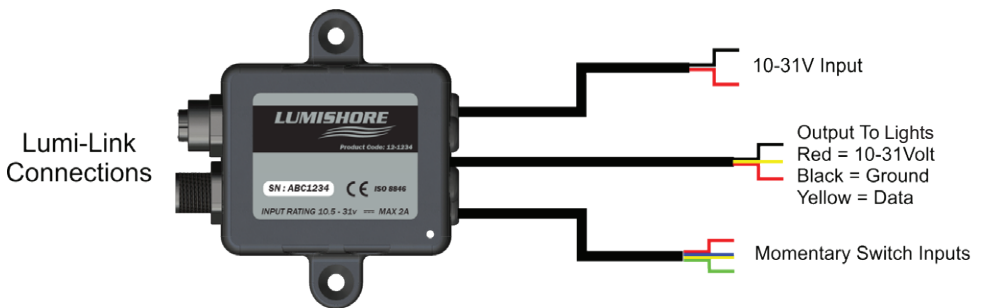

Installation Diagram (Switch Only Operation):

The LUX Light Control Module can be installed as a stand alone control module and operated with momentary switches

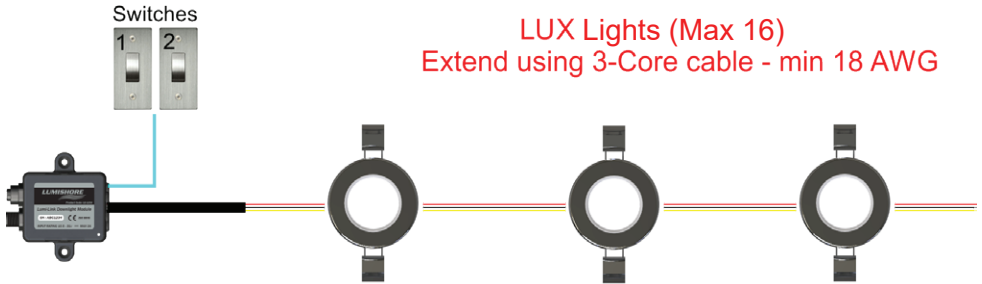

A choice of different switch options are available.....

Option 1

- Switch 1 = On / Off (Hold to dim)
- Switch 2** = Cold White / Neutral White / Warm White

Option 2

- Switch 1 = On / Off (Hold to dim)
- Switch 2** = Cold white /Neutral White/Warm White/Red/Blue/Green/Magenta/Cyan

**Switch 2 is optional

The wiring diagram to connect the switch options above are shown on the following pages. All unused switch wire inputs should be isolated.

Switch Wiring Diagram - On/Off and Preset white colors

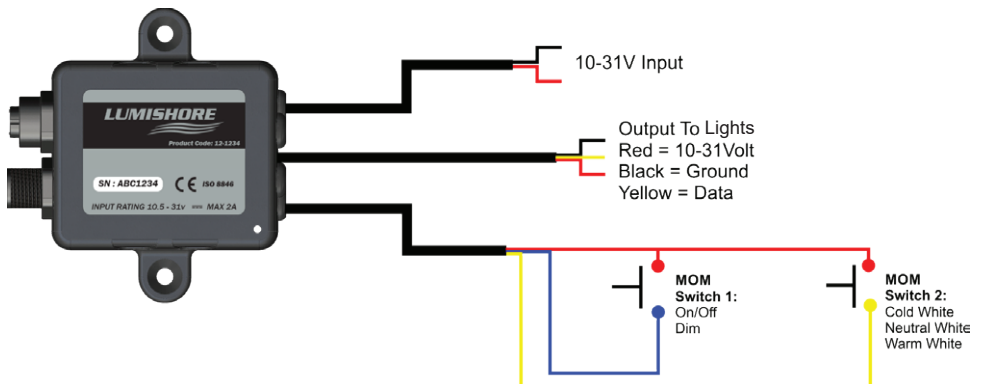

NB: Green Switch Wire = No Connect

Switch Wiring Diagram - On/Off, Preset white colors and RGB

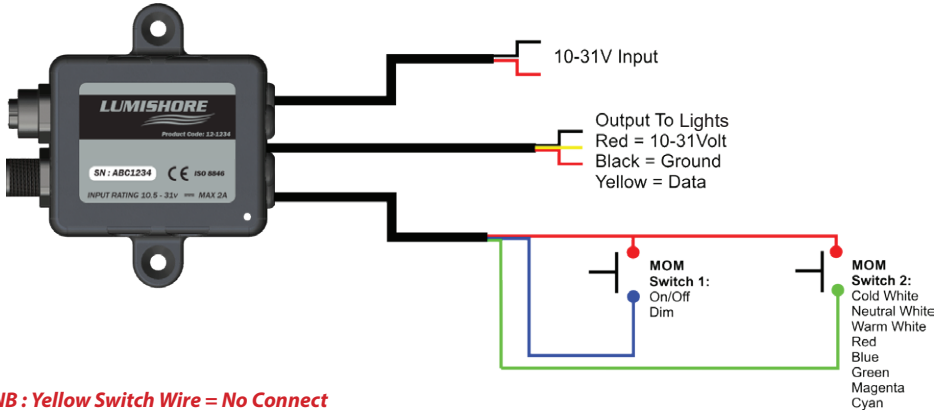

NB : Yellow Switch Wire = No Connect

Installation Diagram (Switch control and Lumi-link Command Center)

The LUX Light Control Module can be used in conjunction with the Lumi-link Command Center and other Lumishore LUX or EOS lighting products to offer complete vessel lighting control from the vessels multifunction display, Lumi-Link Display or Smart device.

Each LUX module can also be controlled from independent momentary switches mounted in the room or dash board. When pressed, the switch removes control from the Lumi-link command center and offers independent On/off control, dimming or preset color selection. To let the Lumi-link command center regain control the associate zone should be powered off and on again at the MFD, smart device or Lumi-Link display.

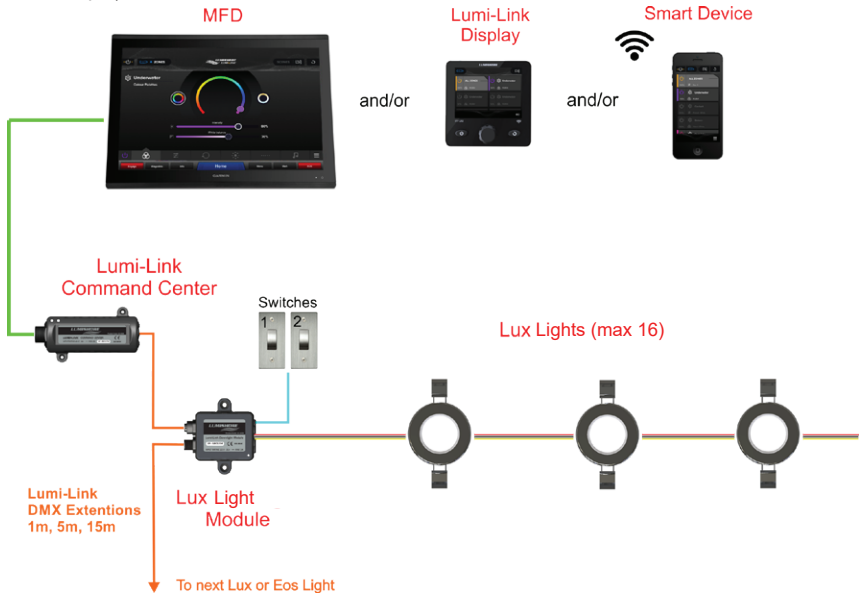

Extension Cables (standard 3-core between Lux Light Module and Lights)

Both Light module and Lights are supplied with 25cm of unterminated 3-core cable. The cable can be extended using standard 3-core cable. All lights should be wired in parallel. Lights can be wired in a daisy chain pattern or in a star pattern. There is a maximum of 16 light per Light module.

Ensure the correct cable gauge is used to avoid issues with voltage drop. Follow ABYC recommendations for no more than 3% voltage drop at 12v and 10% drop at 24v

Note: All connections should be made waterproof

Lights wired in Parallel - Daisy Chain

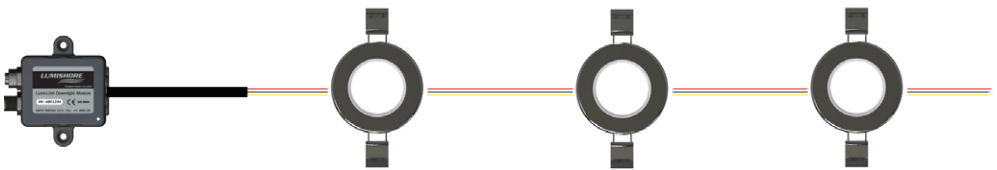

Lights wired in Parallel - Star Pattern

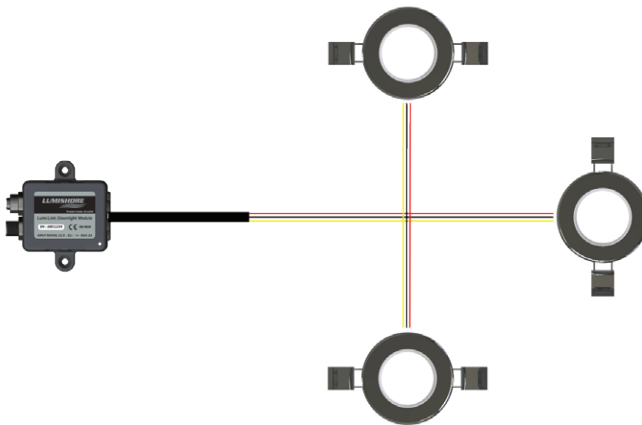

Status LED flash sequence



LED Status	LED Description	Control Module Status
	Solid On	Power OK
	Quick Blink	Data Received (Lumi-Link)
	Single Blink	Switch Input 1 Received
	Two Blinks	Switch Input 2 Received
	Three Blinks	Switch Input 3 Received



Warranty

LUMISHORE Ltd warrants the LUX Light Control Module to be free from defects in workmanship and materials for a period of two years, starting from the date of original purchase. Misuse, abuse, improper installation, neglect, improper shipping, damage caused by disasters such as fire, flood, and lightning, installation by unqualified personnel, unauthorized repair or modification will void this warranty. For the avoidance of confusion and doubt, non-compliance with all installation, maintenance and operating instructions in this document constitute non-conformance with warranty terms.

The LUX Light Control Module is designed to work with Lumishore LUX strip lighting products ONLY, do not use with other Strip light brands, this will invalidate the warranty.